

**PC-22ANALOG
PREPROCESSOR**

&

PC-67 PREAMPLIFIER

User manual

User manual for
PC-22 analog preprocessor

&

PC-67 preamplifier

CONTENTS

Introduction	1
AD524 instrumentation amplifier	2
AD524 features	2
Amplifier operating instructions	2
AD524 input and output offset adjustment	3
The filter	3
Selection of resonant and cutoff frequencies	4
Frequency tuning offset adjustment	4
Filter specifications	4
DIN connector pin connections	5
Interconnections	5
PC-67	8
Test data	9
Circuit diagram	13

Introduction

Transducer-derived signals are often in a form which is unsuitable for direct interfacing to an A/D converter for data acquisition. Signals are often very small and noisy. Such noise will, if not filtered, be amplified and converted with the signal. In many cases, the signal will be so noisy as to be practically useless.

A small signal faces another problem. For example, if a signal in the millivolt range is applied to an A/D converter with an input voltage range of zero to 10 volts, the resolution of the input signal will be very low, due to the A/D's quantisation. The PC-22 is an analog preprocessor board which amplifies small signals, thus significantly improving their resolution when converted to digital form. Amplification from one to one thousand is selectable in software.

The PC-22 caters for the many data acquisition applications which require some form of filtering. It features an allpass function, DC- and AC-coupled lowpass filters, highpass, notch and selective filters. Whether the need is to filter out noise, or to concentrate on one particular frequency band, there is a filter to suit the application. The filters are second order, and are tunable between 10Hz to approximately 18KHz. Filter Q is independently adjustable from 0.7 to 10.

Each PC-22 card will amplify one channel of transducer signal. PC-67 is used to amplify four channels of transducer-derived signals, but with limited filtering. The only filter available on the PC-67 is the DC lowpass filter, which passes DC, and has a fixed 3dB cutoff at 20Hz, with a rolloff of 6dB per octave. Effectively this filter passes all signals below 10Hz. It is ideal for slowly varying signals from thermocouples and strain gauges.

AD524 - the instrumentation amplifier

The AD524 instrumentation amplifier is designed for data acquisition applications under worst-case operating conditions. It was chosen for use in the PC-22 because of its combination of high linearity, high common mode rejection, low offset voltage drift and low noise. It is fully protected for both power-on and power-off fault conditions.

The differential input voltage range of the AD524 is limited to ± 8 volts. This also applies to the output voltage range. Operation outside these ranges will produce inaccurate, non-linear results.

To minimize noise pickup at the amplifier output, connections between the transducer and the preprocessor should be coaxial cable. The PC-22's signal input connector allows for this.

AD524 features

Low noise	0.3 μ V p-p 0.1 Hz - 10Hz
Low non-linearity	0.003% (Gain = 1)
High CMRR	120dB (Gain = 1000)
Low offset voltage drift	0.5 μ V/ $^{\circ}$ C
Gain/bandwidth product	25MHz
Output slew rate	5V/ μ S

Amplifier operating instructions

Gain is selected from software in four ranges: 1, 10, 100 and 1000. Fine adjustment is performed manually from the front panel of the PC-22. This adjustment is by a factor of one to ten. This means that gain is continuously variable from 1 to 1000. It is also possible to obtain gains of over 1000, but this is not recommended. Noise will interfere with the accuracy of measurements.

Gain is selected by applying TTL level logic signals to the gain pins on the PC-22's DIN connector. Each PC-22 requires three lines of an 8255 PPI device for gain switching. If the PC-22 is being used with a data acquisition board such as one of the members of the PC-30 family, which have an on-board 8255, this

can be used for gain switching. Otherwise, an external 8255 board, such as the PC-36, should be used.

On all boards - an 8255 can accommodate up to eight - the gain select pins on the DIN connector are the same. If the demonstration software is being used, the board should be connected as for card 0. The same power connections are used on all PC-22 boards.

DIN connector pin	Port no. on 8255	
C4	C0	Gain of 10
C6	C1	Gain of 100
C8	C2	Gain of 1000

There is no connection for gain = 1.

AD524 input and output offset adjustment

Select a gain of one, and short-circuit the input of the PC-22 card. Measure the voltage between ground and pin 9 or pin 10 of the AD524, and adjust VR2 until this voltage measures 0V.

Select a gain of 1000, and proceed as before. Adjust VR1 to measure 0V.

The filter

The filter is a state variable, second-order filter, with various different filter types selected from a switch on the front panel. Typical responses for these filters are given in the Test Data section.

- APF - Amplification, but no filtering.
- DCPLF - Passes DC, and has a fixed 3dB cutoff at 20Hz, with a rolloff of 6dB per octave.
- NF - AC-coupled notch (bandpass) filter. The notch is adjustable from 10Hz to 18KHz.
- LPF - The 3dB cutoff frequency of this AC-coupled lowpass filter is adjustable from 10Hz to 18KHz, with a rolloff of 12dB per octave.

- HPF - The 3dB cutoff frequency of this highpass filter is adjustable from 10Hz to 18KHz, with a rolloff of 12dB per octave.
- SF - An AC-coupled selective filter, whose resonant frequency is adjustable from 10Hz to 18KHz.

Selection of resonant and cutoff frequencies

These are selected from the front panel. With the fine frequency adjust turned to minimum, the cutoff frequencies are as follows:

1 - 10KHz

2 - 3KHz

3 - 1KHz

4 - 300Hz

5 - 100Hz

6 - 30Hz

7 - 10Hz

These frequencies are approximate, and are measured using the lowpass filter. Slight variations can be expected when using the other filter types. It should be remembered that these are the minimum frequencies available using the fine frequency adjustment on the front panel.

Frequency tuning offset adjustment

Turn off the power and remove IC6 from its socket. Restore power, turn the fine frequency adjust to minimum, and measure the voltage between ground and pin 1 on IC6 socket. Adjust VR3 to get 0V.

Filter specifications

The Q of the filters is adjustable from 0.7 to 10, approximately. If the input peak-peak voltage of the filter - the output of the AD524 - exceeds 8V, the output

signal may be clipped or distorted. Q selection is critical when the input peak-peak voltage of the filter is greater than 6V. High Q under such circumstances may result in clipping at the resonant frequencies. To prevent distortion and clipping, select a lower instrumentation amplifier gain.

The graphs in the Test Data section indicate areas which are critical with respect to high and low Q when high filter input signals are used.

DIN connector pin connections

DIN connector pin	Function	
C2	+5V	PC-30 pin 17
C4, C6, C8	Gain select	
C10, C12, C14, C15	Preprocessor	
C17, C19, C21, C23	output	
C28	-12V	PC-30 pin 3
C30	+12V	PC-30 pin 2
C32	Ground	PC-30 pin 42

Interconnections

One 8255 - or one PC-30 family board - can accommodate up to eight PC-22s. When a PC-30 board is used in conjunction with multiple PC-22s, the connections are as follows:

Card 0		
PC-22	Port	PC-30 pin no.
C4	A0	15
C6	A1	31
C8	A2	14
C10	Chan. 0	20

Card 1		
PC-22	Port	PC-30 pin no.
C4	A3	30
C6	A4	13
C8	A5	29
C12	Chan. 1	8

Card 2		
PC-22	Port	PC-30 pin no.
C4	A6	12
C6	A7	28
C8	B0	43
C14	Chan. 2	24

Card 3		
PC-22	Port	PC-30 pin no.
C4	B1	44
C6	B2	45
C8	B3	27
C15	Chan. 3	7

Card 4		
PC-22	Port	PC-30 pin no.
C4	B4	11
C6	B5	10
C8	B6	26
C17	Chan. 4	23

Card 5		
PC-22	Port	PC-30 pin no.
C4	B7	9
C6	C0	49
C8	C1	48
C19	Chan. 5	6

Card 6		
PC-22	Port	PC-30 pin no.
C4	C2	47
C6	C3	46
C8	C4	50
C21	Chan. 6	22

Card 7		
PC-22	Port	PC-30 pin no.
C4	C5	33
C6	C6	16
C8	C7	32
C23	Chan. 7	5

PC-67

The PC-67 four channel preamplifier has no filtering except for the DCLPF, which is switchable. Use these pinouts in conjunction with the previous section to select the connections to the PC-30 which you require - card 0 = channel A, and so on. Two PC-67 cards can be supported by one PC-30 family board.

Ground		C32	PC-30 pin 42
+12V		C30	PC-30 pin 2
-12V		C28	PC-30 pin 3
+5V		C2	PC-30 pin 17
	X	Y	Z
Gain 1	0	0	0
Gain 10	1	0	0
Gain 100	0	1	0
Gain 1000	0	0	1
Gain A channel			
	X	C4	
	Y	C6	
	Z	C8	

Gain B channel

X	C17
Y	C18
Z	C19

Gain C channel

X	C21
Y	C22
Z	C23

Gain D channel

X	C24 C25
Y	C25 C26
Z	C26 C27

Output A channel	C10	Equivalent PC-22 Card 0
Output B channel	C12	Equivalent PC-22 Card 1
Output C channel	C14	Equivalent PC-22 Card 2
Output D channel	C15	Equivalent PC-22 Card 3

Test data

The preprocessor filter functions were tested with a 5V peak-peak input voltage. The cutoff or resonant frequency was selected at approximately 10KHz.

The instrumentation amplifier was tested by selecting the allpass function of the preprocessor, and applying a DC voltage.

INSTRUMENTATION AMP

Gain = 1

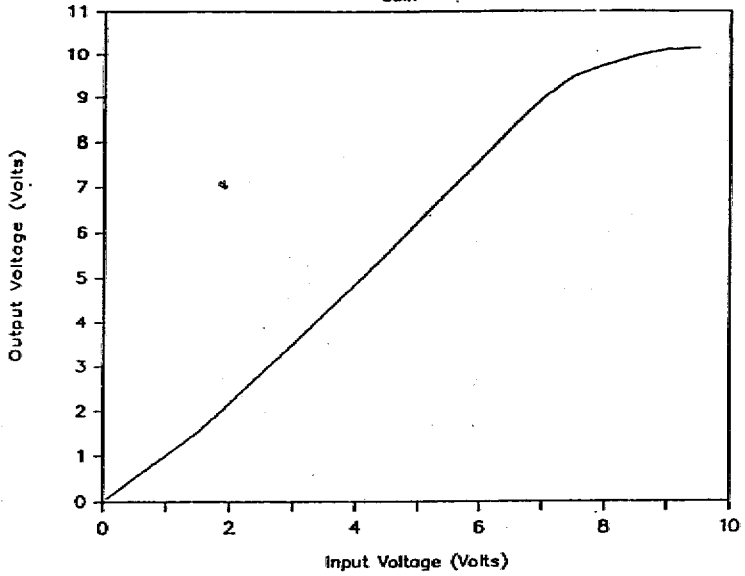

NOTCH FILTER

Medium Q

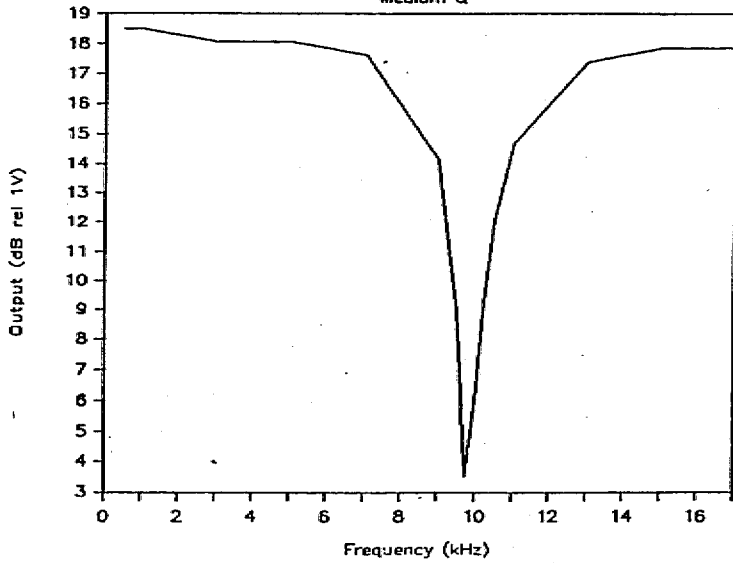

HIGH PASS FILTER

Maximum Q

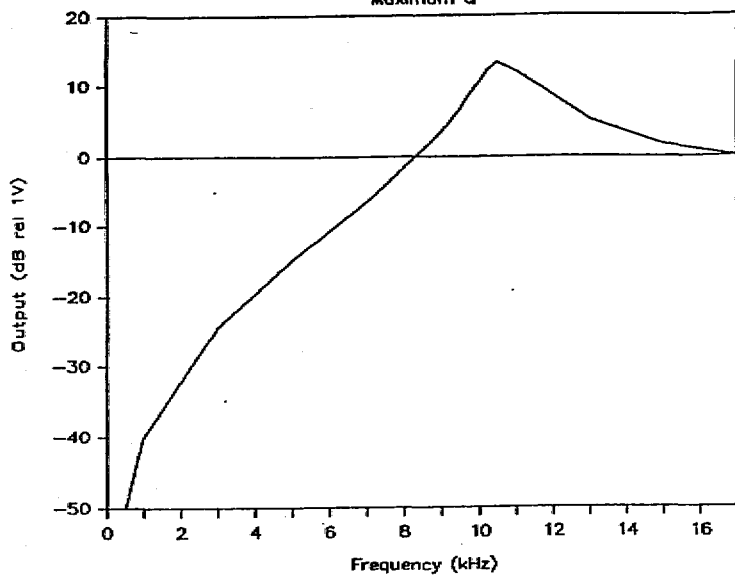

LOW PASS FILTER

Medium Q

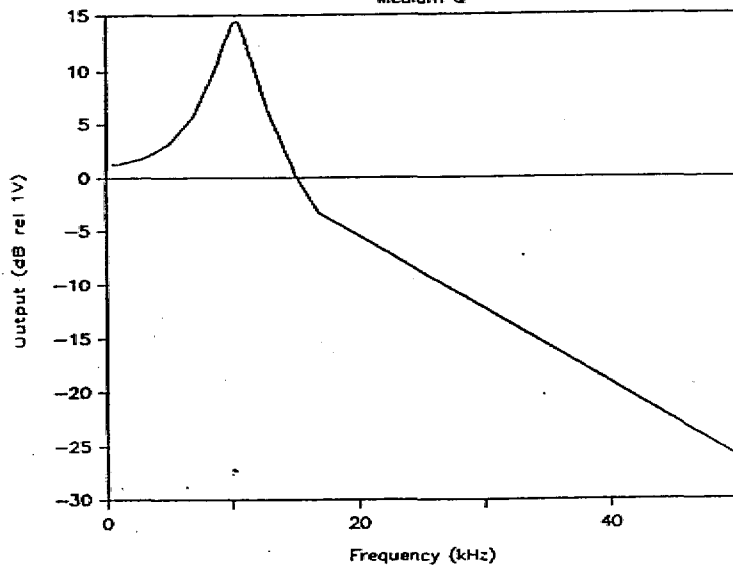

SELECTIVE FILTER

Maximum Q

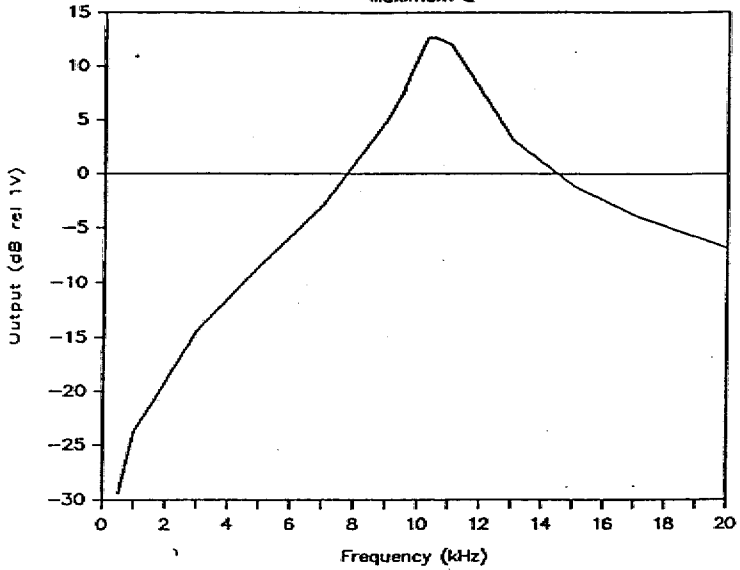

SELECTIVE FILTER

Minimum Q

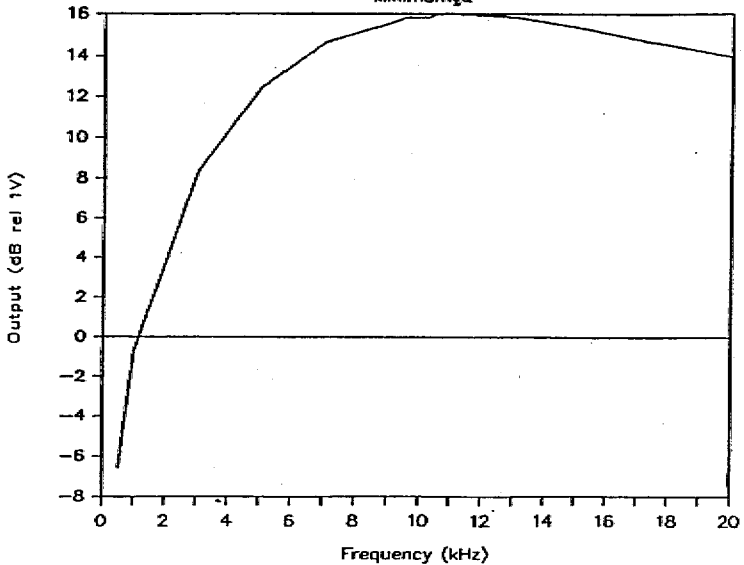

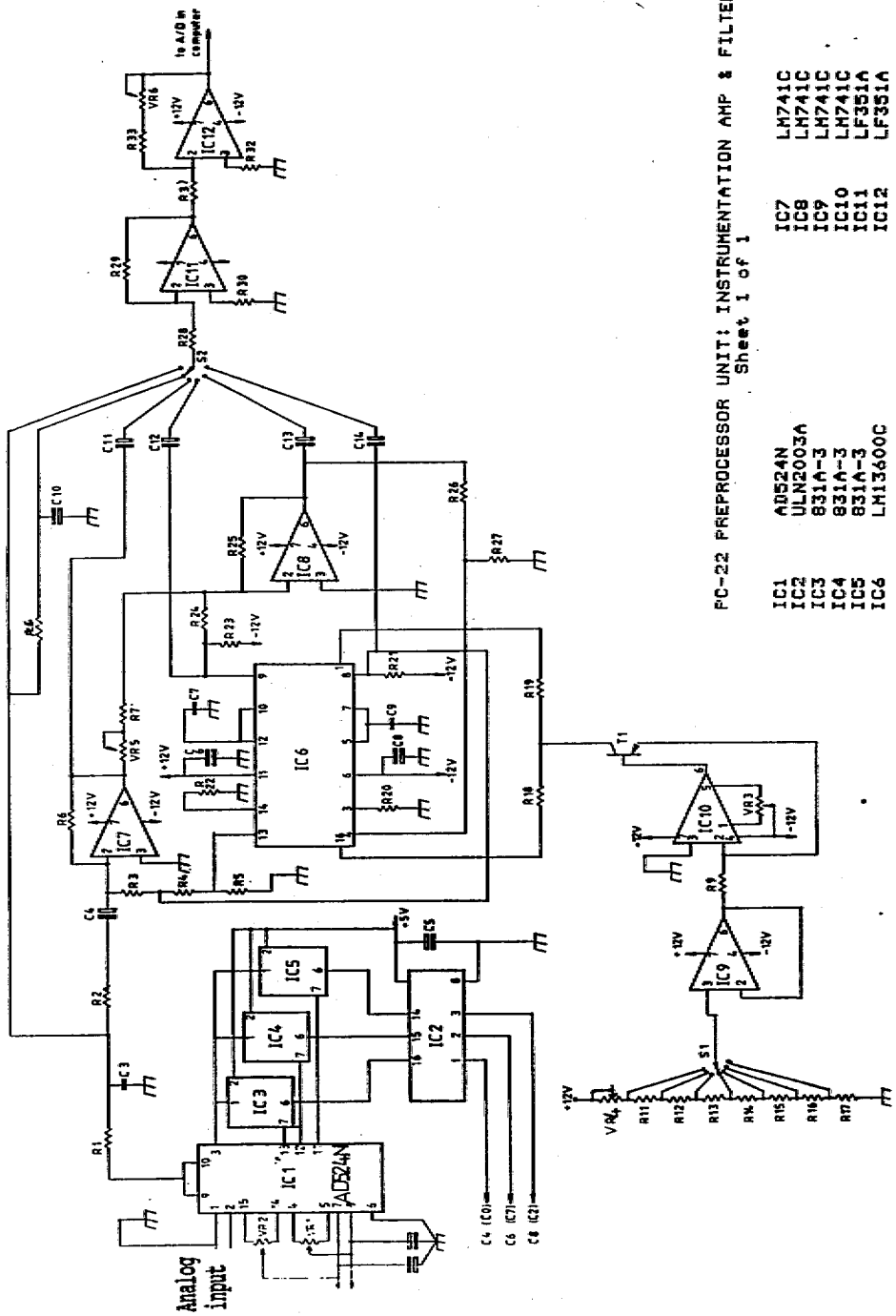

FC-22 PREPROCESSOR UNIT: INSTRUMENTATION AMP & FILTER
Sheet 1 of 1

- | | | | |
|-----|----------|------|--------|
| IC1 | AD524N | IC7 | LM741C |
| IC2 | ULN2003A | IC8 | LM741C |
| IC3 | 831A-3 | IC9 | LM741C |
| IC4 | 831A-3 | IC10 | LM741C |
| IC5 | 831A-3 | IC11 | LF351A |
| IC6 | LM13600C | IC12 | LF351A |