

I/O MODULES

Our line of pluggable input and output modules provide a low cost, versatile method for interconnecting real world analog and digital signals to data acquisition, monitoring, or control systems. All modules provide an optically isolated barrier between sensitive microprocessor or digital logic circuits and field power devices.

In the G5 and OpenLine® packages, analog and digital I/O modules are available with the same pin-out. This gives the flexibility of mixing and matching module types on the same mounting rack or base; making them perfect in applications which require interface to a variety of different sensors and loads.

The case color of the single point modules identify their function. The industry standard for single point I/O module case colors is:

- Digital AC Output Module = Black Case
- Digital DC Output Module = Red Case
- Digital AC Input Module = Yellow Case
- Digital DC Input Module = White Case

DIGITAL OUTPUT MODULES

Digital output modules are used to switch AC and DC loads such as solenoids, motors, or lamps from logic signal levels. Their inputs are directly compatible with TTL or CMOS interface circuitry.

AC output modules have zero voltage turn-on of the load to greatly reduce generated EMI and RFI. They are highly immune to electrical

transients, and have built-in RC snubber networks for increased capability with inductive loads.

DC output modules can operate DC loads over a wide voltage range and have built-in voltage spike protection.

DIGITAL INPUT MODULES

Digital input modules are used to monitor the status of a load or a sensor (such as a limit switch, pressure switch, or temperature switch). The output of these modules is a logic level signal which corresponds to the status of the device being monitored. A high level output signal indicates the load is off (the switch is open). A low level output signal indicates the load is on (the switch is closed). Input modules are designed to give fast, clean switching by providing filtering and hysteresis.

Input and output modules are compatible in that the output of one can drive the input of the other.

UL, CSA AND CE APPROVALS

As one of the world's leading manufacturers of I/O modules, we strive to assure that our products comply with all of the applicable international standards. In doing so, we believe your products will also be readily accepted and easily certified. All modules shown in this section have been tested to UL Standard 508 and are documented in UL file number E58632. Similarly, they have been tested to CSA

Standard 22.2 No. 14-95M and are documented in CSA file LR38763. Additionally, OpenLine® modules were tested and passed CSA 22.2 No. 213-M1987 Class I, Div. 2 Groups A, B, C and D. Parts bearing the CE logo indicate conformance with EN50082-2 and EN50081-2 (89/336/EEC EMC directive) as well as EN60950 (61010-1) for the low voltage directive. Contact Grayhill for copies of our Declaration of Conformity or visit our website. Parts bearing the TÜV logo indicate that they were the agency which performed the EN60950 evaluation.

CONSTRUCTION AND LIFETIME WARRANTY

All of our I/O modules are hard potted with thermally conductive epoxy to withstand harsh industrial environments. The modules provide optical isolation, immunity to mechanical shock and vibration, and operate over a wide temperature range. The module cases are a solvent resistant thermoplastic which meets UL94-V-0 rating. The terminal pins are a tin-plated copper wire. Component selection and surface mount construction allow low operating junction temperatures for long life. Superior design, rigorous testing, and field data give us the confidence to back our I/O modules with the industry's first lifetime warranty.

I/O MODULE WIRING

Analog and digital modules can be placed at any I/O location, however, to minimize the possibility of crosstalk and noise pickup it is a good practice to group similar module types together. 14 or 16 gauge wire is typically used to wire the field devices to the I/O rack terminal block.

PART NUMBER EXPLANATION: Digital I/O Modules

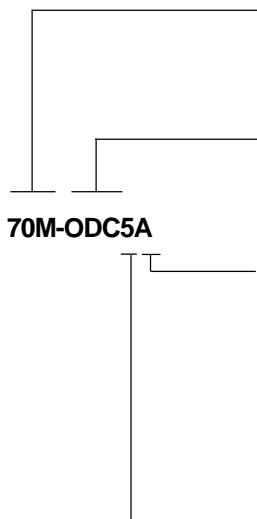

Module Type

- 70 = Digital Module, Standard Package
- 70G = Digital Module, G5 Package
- 70L = Digital Module, OpenLine® Package
- 70M = Digital Module, Mini Package

Function

- OAC = Digital Output AC
- ODC = Digital Output DC
- IAC = Digital Input AC
- IDC = Digital Input DC

Suffix

- | | | | |
|------------|---------------------|--------------------|--------------------------|
| AC Inputs: | Blank = 120 Vac | A = 220 Vac | |
| DC Inputs: | Blank = 3-32 Vdc | B = Fast Switching | NP = 15-32 Vac/10-32 Vdc |
| | G = 35-60 Vac/Vdc | D = 2.5-28 Vdc | K = 2.5-16 Vdc |
| | L = Inductive loads | S = Dry Contacts | |

- | | | | |
|-------------|--------------------------------|-----------------------|-----------------------|
| AC Outputs: | Blank = 120 Vac | A = 220 Vac | A-11 = Non-Zero Cross |
| | MA = 120 Vac, Manual Override | A-5 = Normally Closed | |
| | AMA = 240 Vac, Manual Override | | |

- | | | |
|-------------|--------------------------------|-------------------------------|
| DC Outputs: | Blank = 3-60 Vdc Fast | A = 4-200 Vdc R = Dry Contact |
| | MA = 3-60 Vdc, Manual Override | B = 3-60 Vdc, Low Leakage |

Logic Supply Voltage or Range

- Digital Modules: Blank = 4.5-28 Vdc (OpenLine®)
- 5 Vdc, 15 Vdc, 24 Vdc = Logic Supply Voltage (Standard, Mini, G5)
- Analog Modules: 4.75-5.25 Vdc

DIMENSIONS: OpenLine® Digital Modules

Dimensions shown in inches (and millimeters).
Tolerances are ± .010 (0,25) unless indicated otherwise.

Module Type I/O Module Pin #	Output Function	Input Function
1	Output A+	Input A+
2	Output A-	Input A-
3	Output B+	Input B+
4	Output B-	Input B-
5	Logic Gnd	Logic Gnd
6	Vcc	Vcc
7	Ch. A Input	Ch. A Status
8	Ch. B Input	Ch. B Status
9	Module ID	Module ID

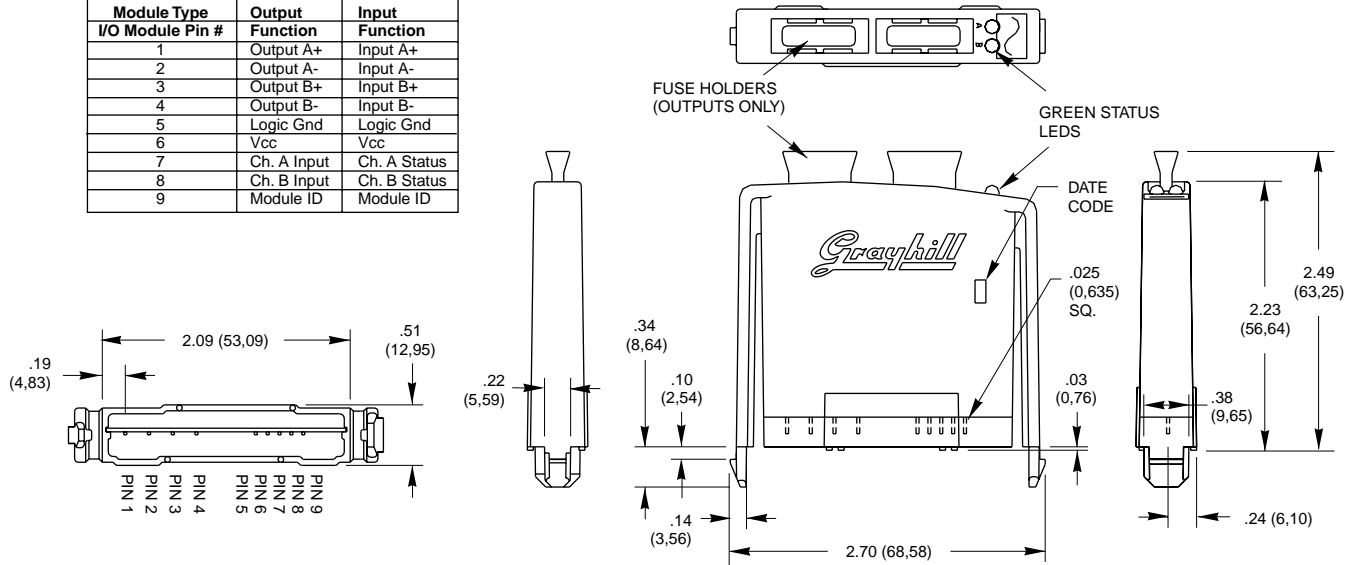

Note: For PC board layout information, request Bulletin #745

DIMENSIONS: G5 Digital Modules

Dimensions shown in inches (and millimeters).
Tolerances are ± .010 (0,25) unless indicated otherwise.

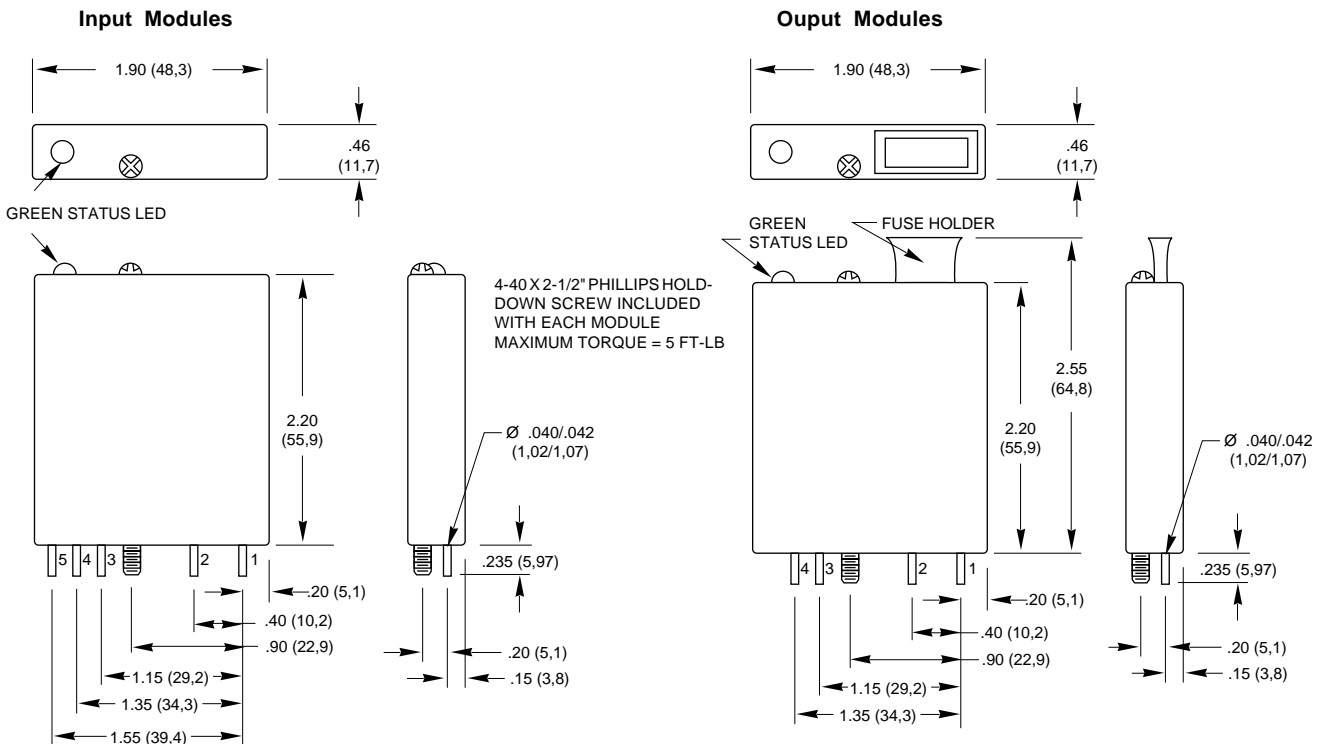

I/O Modules

DIMENSIONS: Standard and Miniature Digital Modules

Dimensions shown in inches (and millimeters).
Tolerances are $\pm .010$ (0,25) unless indicated otherwise.

Standard Module

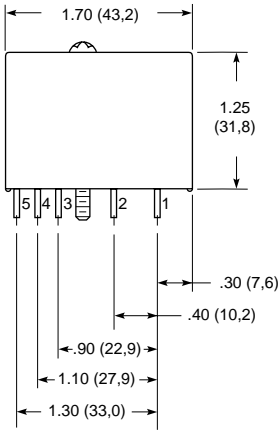
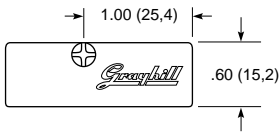

4-40 X 1-1/2" PHILLIPS HOLD-DOWN SCREW INCLUDED WITH EACH MODULE
MAXIMUM TORQUE = 5 FT-LB

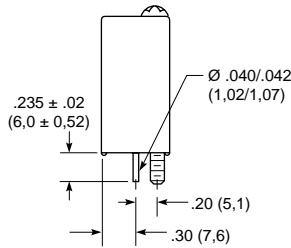

OUTPUT MODULES HAVE ONLY TERMINALS NUMBER 1-4

Miniature Module

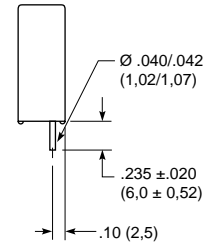
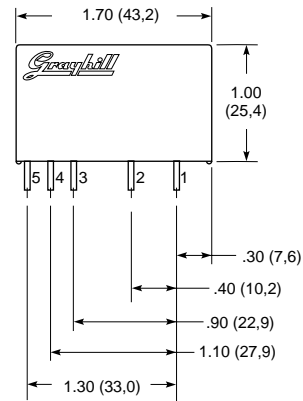
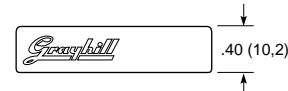

OUTPUT MODULES HAVE ONLY TERMINALS NUMBER 1-4

WIRING DIAGRAM: Digital I/O Modules

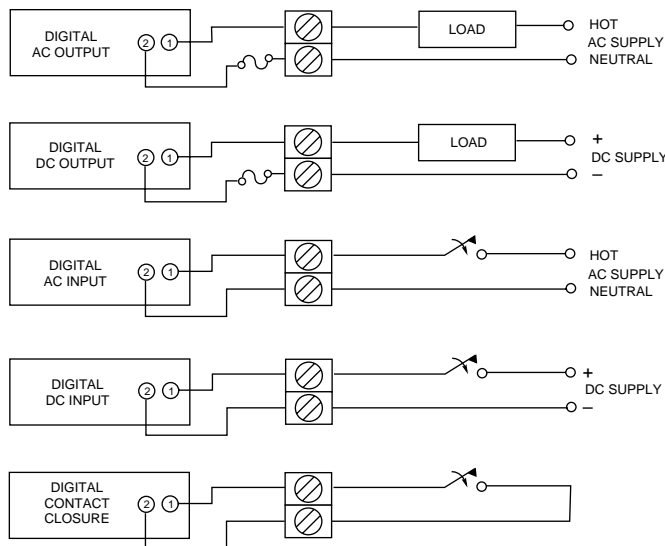

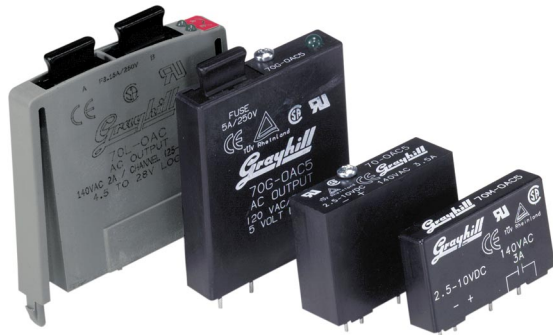
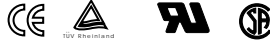

70L-OAC 70G-OAC 70-OAC 70M-OAC

Maximum Current Versus Ambient Temperature

The chart indicates continuous current to limit the junction temperatures to 100°C. Information is based on steady state heat transfer in a 2 cubic foot sealed enclosure.

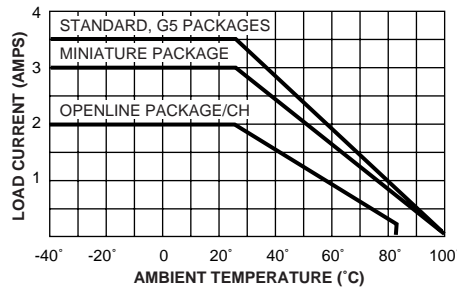

Figure 1

FEATURES

- Transient Protection: Meets the requirements of IEEE 472, "Surge Withstanding Capability Test"
- SPST, Normally Open
- Zero Crossing Turn-On
- UL, CSA, CE, TÜV Certified
- Optical Isolation
- OpenLine® and G5 Modules Provide Replaceable 5x20 mm Glass Fuses
- Built-in Status LED
- Lifetime Warranty

DIMENSIONS

For complete dimensional drawings, see pages H-4 or H-5.

FUSES

G5 Fuses are 5 Amp Littelfuse part number 217005 or equivalent. OpenLine® fuses are 3.15 Amp Littelfuse part number 217315.

Fuse kits available, see page H-106.

CIRCUITRY

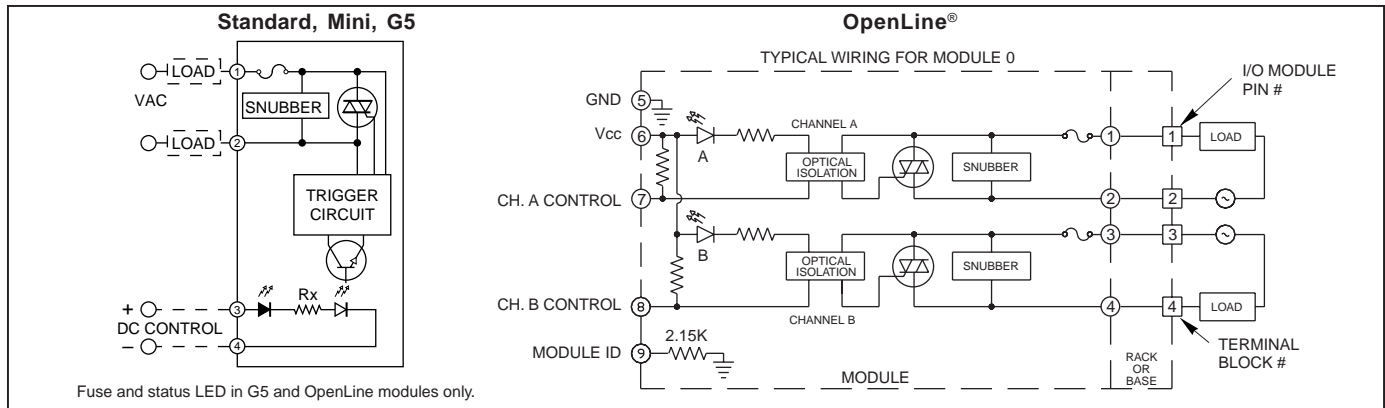

SPECIFICATIONS: By Package Style

Package Style		Std (70-)	Mini (70M-)	G5 (70G-)	OL (70L-)
Specifications	Units				
Load Current Range ¹	A rms	0.03 to 3.5	0.03 to 3.0	0.03 to 3.5	0.03 to 2.0/CH
Maximum 1 Cycle Surge ²	A rms	80	80	80	30
Maximum Turn-On-Time (60 Hz) ³	mSec	8.33	8.33	8.33	8.33
Maximum Turn-Off Time (60 Hz)	mSec	8.33	8.33	8.33	8.33
Static dv/dt ⁷	V/μsec	3000	3000	3000	3000
Typ. Power Dissipation	W/A	1.0	1.0	1.0	1.0
Isolation Voltage ⁴	V rms	4000	4000	4000	2500
Vibration ⁵		MIL-STD-202	MIL-STD-202	MIL-STD-202	IEC68-2-6
Mechanical Shock ⁶		MIL-STD-202	MIL-STD-202	MIL-STD-202	IEC68-2-27
Storage Temp. Range	°C	-40 to 125	-40 to 125	-40 to 125	-40 to 100
Operating Temp. Range	°C	-40 to 100	-40 to 100	-40 to 100	-40 to 85
Warranty		Lifetime	Lifetime	Lifetime	Lifetime

¹ See Figure 1 for derating.
² Maximum 10 cycle surge is 50% of 1 cycle surge. Application of maximum surge may not be repeated until module temperature has returned to its steady state value.
³ Except 70-OAC5A5 which is 200 μSec and 70-OAC5A-11, 70M-OAC5A-11, and 70G-OAC5A-11 which are 100 μSec.
⁴ Field to logic and channel-to-channel if Grayhill racks are used.
⁵ MIL-STD-202, Method 204, 20, 10-2000 Hz or IEC68-2-6, 0.15 mm/sec², 10-150 Hz.
⁶ MIL-STD-202, Method 213, Condition F, 1500G or IEC68-2-27, 11 mS, 15g.
⁷ Except part numbers with -L suffix which have a dv/dt rating of 200 V/μSec.

SPECIFICATIONS: By Part Number
Standard and Miniature Modules

Type/Function		Grayhill Part Number					
Miniature, Normally Open, Random Turn-on			70M-OAC5A-11				
Miniature, Normally Open, Zero Voltage Turn-on (ZVT)		70M-OAC5	70M-OAC5A	70M-OAC15	70M-OAC15A	70M-OAC24	70M-OAC24A
Miniature, Normally Open, ZVT, Inductive Load		70M-OAC5-L	70M-OAC5A-L				
Standard, Normally Closed, Random Turn-on			70-OAC5A5				
Standard, Normally Open, Random Turn-on			70-OAC5A-11				70-OAC24A-11
Standard, Normally Open, ZVT		70-OAC5	70-OAC5A	70-OAC15	70-OAC15A	70-OAC24	70-OAC24A
Standard, Normally Open, ZVT, Inductive Load		70-OAC5-L	70-OAC5A-L				
Specifications	Units						
Nominal Line Voltage	Vac	120	240	120	240	120	240
Load Voltage Range	Vac	24-140	24-280	24-140	24-280	24-140	24-280
Minimum Peak Blocking Voltage	Volts	400	600	400	600	400	600
Maximum Off-state Leakage @ 60Hz	mA, rms	2	4	2	4	2	4
Nominal Logic Voltage (Vcc)	Vdc	5	5	15	15	24	24
Logic Voltage Range	Vdc	2.5-10	2.5-10	10-18	10-18	15-30	15-30
Max. Logic Supply Current @ Nominal Vcc	mA	16	16	9	9	9	9
Nominal Input Resistance (Rx)	Ω	240	240	1800	1800	2700	2700
Minimum Drop Out Voltage	Vdc	1	1	1	1	1	1
Maximum Reverse Logic Voltage	Vdc	-5	-5	-5	-5	-5	-5

G5 Modules

Type/Function		Grayhill Part Number					
G5 Fusible, Normally Open, ZVT		70G-OAC5	70G-OAC5A	70G-OAC15	70G-OAC15A	70G-OAC24	70G-OAC24A
G5 Fusible, Normally Open, ZVT, Inductive Load		70G-OAC5-L	70G-OAC5A-L	70G-OAC15-L	70G-OAC15A-L	70G-OAC24-L	70G-OAC24A-L
G5 Fusible, Normally Open, Random Turn-on			70G-OAC5A-11				
Specifications	Units						
Nominal Line Voltage	Vac	120	240	120	240	120	240
Load Voltage Range	Vac	24-140	24-280	24-140	24-280	24-140	24-280
Minimum Peak Blocking Voltage	Volts	400	600	400	600	400	600
Maximum Off-state Leakage @ 60Hz	mA, rms	2	4	2	4	2	4
Nominal Logic Voltage (Vcc)	Vdc	5	5	15	15	24	24
Logic Voltage Range	Vdc	4-6	4-6	8-20	8-20	18-32	18-32
Max. Logic Supply Current @ Nominal Vcc	mA	20	20	12	12	8	8
Nominal Input Resistance (Rx)	W	100	100	1000	1000	2700	2700
Minimum Drop Out Voltage	Vdc	1	1	1	1	1	1
Maximum Reverse Logic Voltage	Vdc	-5	-5	-5	-5	-5	-5

OpenLine® Modules

Type/Function		Grayhill Part Number	
Dual, Fusible, Normally Open, ZVT		70L-OAC	70L-OACA
Dual, Fusible, Normally Open, ZVT, Inductive Load		70L-OAC-L	70L-OACA-L
Specifications	Units		
Nominal Line Voltage	Vac	120	240
Load Voltage Range	Vac	24-140	24-280
Minimum Peak Blocking Voltage	Volts	600	600
Maximum Off-State Leakage @ 60 Hz	mA, rms	2	4
Nominal Logic Voltage	Vdc	5	5
Logic Voltage Range	Vdc	4.5-28	4.5-28
Max. Logic Supply Current @ Nominal Vcc	mA	7/CH	7/CH
Module ID Resistance to Logic Ground	Ω	2.15K	2.15K
Minimum Drop Out Voltage	Vdc	1	1

Available from your local Grayhill Distributor. For prices and discounts, contact a local Sales Office, an authorized local Distributor or Grayhill.

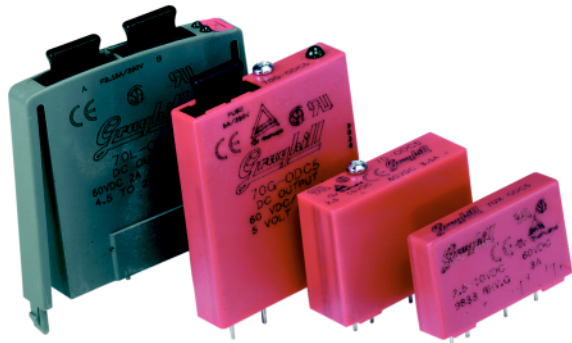

70L-ODC 70G-ODC 70-ODC 70M-ODC

FEATURES

- Transient Protection: Meets the requirements of IEEE 472, "Surge Withstanding Capability Test"
- SPST, Normally Open
- UL Recognized, CSA Certified, CE Mark, TÜV (see Engineering Information)
- Optical Isolation
- OpenLine® and G5 Modules Provide Replaceable 5 x 20 mm Glass Fuse
- Built-in Status LED
- Lifetime Warranty

Maximum Current Versus Ambient Temperature

The chart indicates continuous current to limit the junction temperatures to 115°C. Information is based on steady state heat transfer in a 2 cubic foot sealed enclosure.

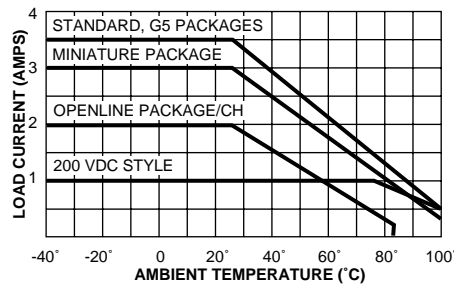

Figure 1

DIMENSIONS

For complete dimensional drawings, see pages H-4 or H-5.

FUSES

G5 Fuses are 5 Amp Littelfuse part number 217005 or equivalent. OpenLine® fuses are 3.15 Amp Littelfuse part number 217315.

Fuse kits available, see page H-106.

CIRCUITRY

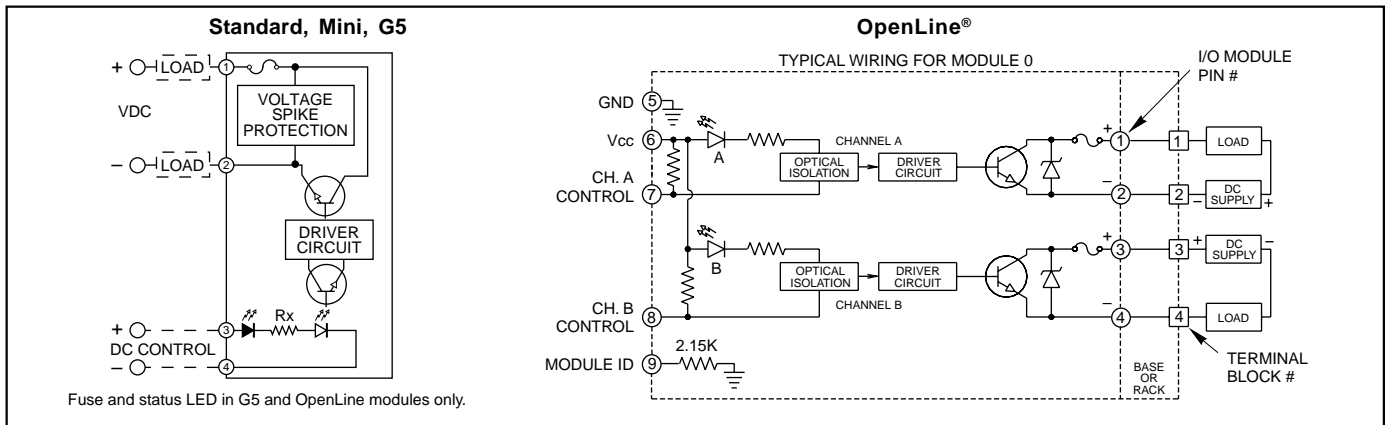

Fuse and status LED in G5 and OpenLine modules only.

SPECIFICATIONS: By Package Style

Package Style		Std (70-)	Mini (70M-)	G5 (70G-)	OL (70L-)
Specifications	Units				
Load Current Range ¹	A	0.02-3.5	0.02-3.0	0.02-3.5	0.02-2.0/CH
Surge Current for 1 Sec.	A	5	5	5	5
Maximum Reverse Logic Voltage	Vdc	-5	-5	-5	-5
Isolation Voltage ²	Vrms	4000	4000	4000	2500
Vibration ³		MIL-STD-202	MIL-STD-202	MIL-STD-202	IEC68-2-6
Mechanical Shock ⁴		MIL-STD-202	MIL-STD-202	MIL-STD-202	IEC68-2-27
Storage Temp. Range	°C	-40 to 125	-40 to 125	-40 to 125	-40 to 100
Operating Temp. Range	°C	-40 to 100	-40 to 100	-40 to 100	-40 to 85
Warranty		Lifetime	Lifetime	Lifetime	Lifetime

¹ See Figure 1 for derating.

² Field to logic and channel-to-channel if Grayhill racks are used.

³ MIL-STD-202, Method 204, 20 G, 10-2000 Hz or IEC68-2-6, 0.15 mm/sec², 10-150 Hz.

⁴ MIL-STD-202, Method 213, Condition F, 1500 G or IEC68-2-27, 11 mS, 15g.

SPECIFICATIONS: By Part Number
Standard and Miniature Modules

Type/Function		Grayhill Part Number						
Miniature, Normally Open		70M-ODC5	70M-ODC5A	70M-ODC5B	70M-ODC15	70M-ODC15B	70M-ODC24	70M-ODC24B
Standard, Normally Open		70-ODC5	70-ODC5A	70-ODC5B	70-ODC15	70-ODC15B	70-ODC24	70-ODC24B
Specifications	Units							
Maximum Line Voltage	Vdc	60	200	60	60	60	60	60
Load Voltage Range	Vdc	3-60	4-200	3-60	3-60	3-60	3-60	3-60
Max. Off-State Leakage @ Max. Line	mA	1.5	0.01	0.01	1.5	0.01	1.5	0.01
Maximum Turn-On Time	µSec	20	75	75	20	75	20	75
Maximum Turn-Off Time	µSec	50	750	500	50	500	50	500
Typ. Power Dissipation	W/A	1	1.5	1	1	1	1	1
Clamping Voltage	Vdc	80	360	80	80	80	80	80
Nominal Logic Voltage (Vcc)	Vdc	5	5	5	15	15	24	24
Logic Voltage Range	Vdc	2.5-10	2.5-9	2.5-10	10-18	10-18	15-30	15-30
Maximum Logic Supply Current @ Nominal Vcc	mA	14	18	14	9	9	9	9
Nominal Input Resistance (Rx)	Ω	300	220	300	1800	1800	2700	2700
Minimum Drop Out Voltage	Vdc	1	1	1	1	1	1	1

G5 and OpenLine® Modules

Type/Function		Grayhill Part Number						
Fusible, Normally Open		70G-ODC5	70G-ODC5A	70G-ODC5B	70G-ODC15	70G-ODC15B	70G-ODC24	70G-ODC24B
Specifications	Units							
Maximum Line Voltage	Vdc	60	200	60	60	60	60	60
Load Voltage Range	Vdc	3-60	4-200	3-60	3-60	3-60	3-60	3-60
Max. Off-State Leakage @ Max. Line	mA	1.5	0.01	0.01	1.5	0.01	1.5	0.01
Maximum Turn-On Time	µSec	20	75	75	20	75	20	75
Maximum Turn-Off Time	µSec	50	750	500	50	500	50	500
Typ. Power Dissipation	W/A	1	1.5	1	1	1	1	1
Clamping Voltage	Vdc	80	360	80	80	80	80	80
Nominal Logic Voltage (Vcc)	Vdc	5	5	5	15	15	24	24
Logic Voltage Range	Vdc	4-6	4-6	4-6	10-20	10-20	18-32	18-32
Maximum Logic Supply Current @ Nominal Vcc	mA	13	13	13	9	9	9	9
Nominal Input Resistance (Rx)	Ω	150	150	150	1500	1500	2700	2700
Minimum Drop Out Voltage	Vdc	1	1	1	1	1	1	1

OpenLine® Modules

Type/Function		Grayhill Part Number		
Dual, Fusible, Normally Open		70L-ODC	70L-ODCA	70L-ODCB
Specifications	Units			
Maximum Line Voltage	Vdc	60	200	60
Load Voltage Range	Vdc	3-60	4-200	3-60
Max. Off-State Leakage @ Max. Line	mA	1.5	.01	.01
Maximum Turn-On Time	µSec	20	75	75
Maximum Turn-Off Time	µSec	50	750	500
Typ. Power Dissipation	WA	1	1.5	1
Clamping Voltage	Vdc	80	360	80
Nominal Logic Voltage (Vcc)	Vdc	5	5	5
Logic Voltage Range	Vdc	4.5-28	4.5-28	4.5-28
Maximum Logic Supply Current @ Nominal Vcc	mA	7/CH	7/CH	7/CH
Module ID Resistance to Logic Ground	Ω	2.15K	2.15K	2.15K
Minimum Drop Out Voltage	Vdc	1	1	1

Available from your local Grayhill Distributor.
For prices and discounts, contact a local Sales Office, an authorized local Distributor or Grayhill.

I/O Modules



FEATURES

- Transient Protection: Meets the requirements of IEEE 472, "Surge Withstanding Capability Test"
- UL, CSA, CE, TÜV Certified (TÜV not available on OpenLine)
- Optical Isolation
- OpenLine® and G5 Modules have Built-in Status LED
- Lifetime Warranty

DIMENSIONS

For complete dimensional drawings, see pages H-4 or H-5.

CIRCUITRY

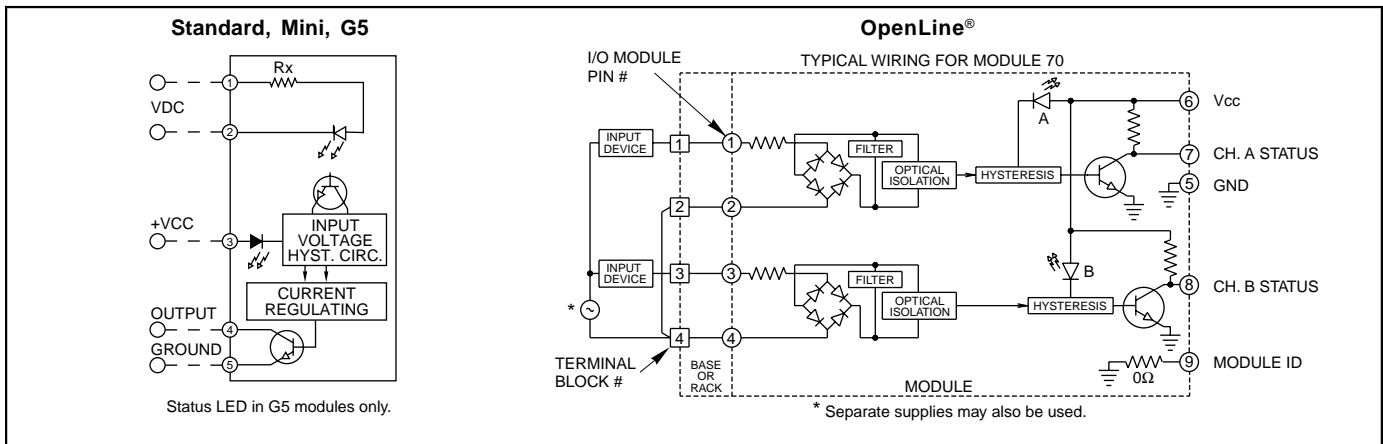

SPECIFICATIONS: By Package Style

Package Style		Std (70-)	Mini (70M-)	G5 (70G-)	OL (70L-)
Specifications	Units				
Output Current Range	mA	1-50	1-50	1-50	1-50
Minimum Output Breakdown Voltage	Vdc	50	50	50	50
Maximum Turn-On Time	mS	20	20	20	20
Maximum Turn-Off Time	mS	20	20	20	20
Isolation Voltage ¹	Vrms	4000	4000	4000	2500
Vibration ²		MIL-STD-202	MIL-STD-202	MIL-STD-202	IEC68-2-6
Mechanical Shock ³		MIL-STD-202	MIL-STD-202	MIL-STD-202	IEC68-2-27
Storage Temp. Range	°C	-40 to +125	-40 to +125	-40 to +125	-40 to +100
Operating Temp. Range	°C	-40 to +100	-40 to +100	-40 to +100	-40 to +85
Warranty		Lifetime	Lifetime	Lifetime	Lifetime

¹ Field to logic and channel-to-channel if Grayhill racks are used.

² MIL-STD-202, Method 204, 20 G, 10-2000 Hz or IEC68-2-6, 0.15 mm/sec², 10-150 Hz.

³ MIL-STD-202, Method 213, Condition F, 1500 G or IEC68-2-27, 11 mS, 15g.

SPECIFICATIONS: By Part Number
Standard and Miniature Modules

Type/Function		Grayhill Part Number					
Miniature		70M-IAC5	70M-IAC5A	70M-IAC15	70M-IAC15A	70M-IAC24	70M-IAC24A
Standard		70-IAC5	70-IAC5A	70-IAC15	70-IAC15A	70-IAC24	70-IAC24A
Specifications	Units						
Nominal Input Voltage	Vac	120	240	120	240	120	240
Input Voltage Range ¹	Vac/Vdc	90-140	180-280	90-140	180-280	90-140	180-280
Input Current @ Maximum Input Voltage	mA, rms	8	6	8	6	8	6
Nominal Input Resistance (Rx)	Ω	22K	60K	22K	60K	22K	60K
Maximum Pick-Up Voltage (Output Low)	Vac	90	180	90	180	90	180
Minimum Drop-Out Voltage (Output High)	Vac	25	50	25	50	25	50
Nominal Logic Voltage (Vcc)	Vdc	5	5	15	15	24	24
Logic Voltage Range	Vdc	3-6	3-6	8-18	8-18	15-30	15-30
Max. Logic Supply Current @ Nominal Vcc	mA	10	10	10	10	10	10

G5 Modules

Type/Function		Grayhill Part Number					
G5, Status LED		70G-IAC5	70G-IAC5A	70G-IAC15	70G-IAC15A	70G-IAC24	70G-IAC24A
Specifications	Units						
Nominal Input Voltage	Vac	120	240	120	240	120	240
Input Voltage Range ¹	Vac/Vdc	0-140	0-280	0-140	0-280	0-140	0-280
Input Current @ Maximum Input Voltage	mA, rms	8	6	8	6	8	6
Nominal Input Resistance (Rx)	Ω	22K	60K	22K	60K	22K	60K
Maximum Pick-Up Voltage (Output Low)	Vac	90	180	90	180	90	180
Minimum Drop-Out Voltage (Output High)	Vac	25	50	25	50	25	50
Nominal Logic Voltage (Vcc)	Vdc	5	5	15	15	24	24
Logic Voltage Range	Vdc	4.5-6	4.5-6	10-18	10-18	17-30	17-30
Max. Logic Supply Current @ Nominal Vcc	mA	10	10	10	10	10	10

OpenLine® Modules

Type/Function		Grayhill Part Number	
Dual, Status LED		70L-IAC	70L-IACA
Specifications	Units		
Nominal Input Voltage	Vac	120	240
Input Voltage Range ¹	Vac/Vdc	0-140	0-280
Input Current @ Max. Input Voltage	mA, rms	8	6
Nominal Input Resistance (Rx)	Ω	22K	64K
Max. Pick-Up Voltage (Output Low)	Vac	90	180
Min. Drop-Out Voltage (Output High)	Vac	25	50
Nominal Logic Voltage (Vcc)	Vdc	5	5
Logic Voltage Range	Vdc	4.5-28	4.5-28
Max. Logic Supply Current @ Nominal Vcc	mA	6/CH	6/CH
Module ID Resistance to Logic Ground	Ω	0	0

Available from your local Grayhill Distributor.
 For prices and discounts, contact a local Sales Office, an authorized local Distributor or Grayhill.

¹ For input voltages in the range of 15-32 Vac, or 35-60 Vac, see DC input Modules with the NP or G suffix.



70L-IDC

70G-IDC

70-IDC

70M-IDC



FEATURES

- Fast Switching Polarized Input Types
- UL, CSA, CE, TÜV Certified (TÜV not available on OpenLine®)
- Optical Isolation
- OpenLine® and G5 Modules have Built-in Status LED

DIMENSIONS

For complete dimensional drawings, see pages H-4 or H-5.

CIRCUITRY

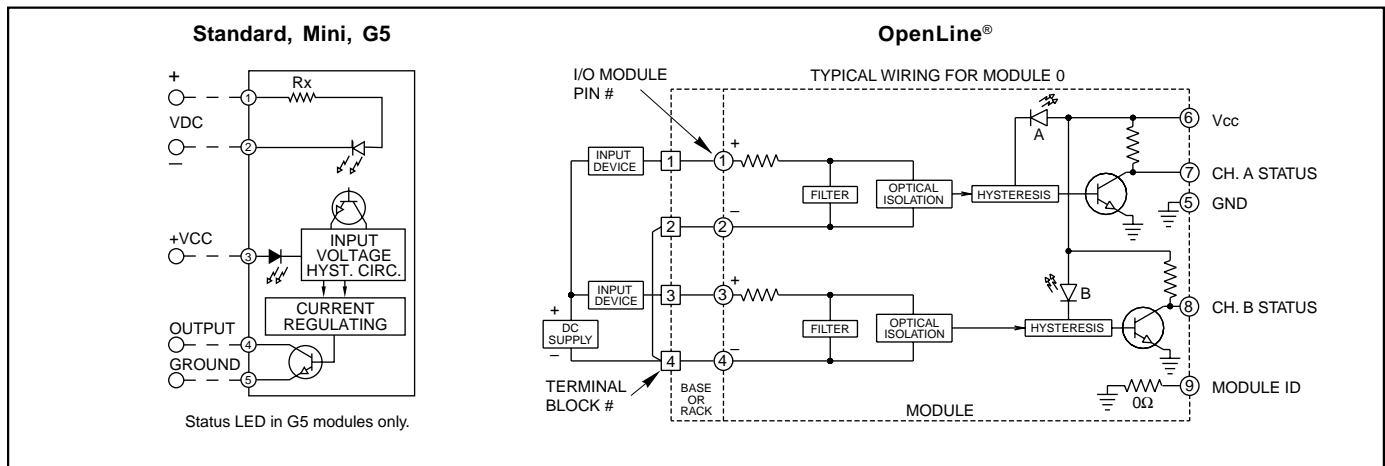

SPECIFICATIONS: By Package Style

Package Style		Std (70-)	Mini (70M-)	G5 (70G-)	OL (70L-)
Specifications	Units				
Output Current Range	mA	1-50	1-50	1-50	1-50
Minimum Output Breakdown Voltage	Vdc	50	50	50	50
Isolation Voltage ¹	Vrms	4000	4000	4000	2500
Vibration ²		MIL-STD-202	MIL-STD-202	MIL-STD-202	IEC68-2-6
Mechanical Shock ³		MIL-STD-202	MIL-STD-202	MIL-STD-202	IEC68-2-27
Storage Temp. Range	°C	-40 to 125	-40 to 125	-40 to 125	-40 to 100
Operating Temp. Range	°C	-40 to 100	-40 to 100	-40 to 100	-40 to 85
Warranty		Lifetime	Lifetime	Lifetime	Lifetime

¹ Field to logic and channel-to-channel if Grayhill racks are used.

² MIL-STD-202, Method 204, 20G, 10-2000 Hz or IEC68-2-6, 0.15 mm/sec², 10-150 Hz.

³ MIL-STD-202, Method 213, Condition F, 1500G or IEC68-2-27, 11 mS, 15g.

SPECIFICATIONS: By Part Number
Standard and Miniature Modules

Type/Function		Grayhill Part Number				
Miniature, Polarized		70M-IDC5			70M-IDC15	70M-IDC24
Standard, Non-Polarized		70-IDC5	70-IDC5B	70-IDC5K	70-IDC15	70-IDC24
Specifications	Units					
Maximum Input Voltage	Vdc	32	32	16	32	32
Input Voltage Range ¹	Vdc	3-32	3-32	2.5-16	3-32	3-32
Input Current @ Maximum Input Voltage	mA	18	18	30	18	18
Maximum Turn-On Time	mSec	0.20	0.050	0.025	0.20	0.20
Maximum Turn-Off Time	mSec	0.40	0.075	0.030	0.40	0.40
Nominal Input Resistance (Rx)	Ω	1.8K	1.8K	500	1.8K	1.8K
Maximum Pick-Up Voltage (Output Low)	Vdc	3	3	2.5	3	3
Minimum Drop-Out Voltage (Output High)	Vdc	1	1	1	1	1
Nominal Logic Voltage (Vcc)	Vdc	5	5	5	15	24
Logic Voltage Range	Vdc	3-6	3-6	3.5-6	8-18	15-30
Max. Logic Supply Current @ Nominal Vcc	mA	10	18	18	10	10

G5 Modules

Type/Function		Grayhill Part Number					
G5, Polarized, Status LED		70G-IDC5	70G-IDC5B	70G-IDC5D	70G-IDC5K	70G-IDC15	70G-IDC24
Specifications	Units						
Maximum Input Voltage	Vdc	32	32	28	16	32	32
Input Voltage Range ¹	Vdc	3-32	3-32	2.5-28	2.5-16	3-32	3-32
Input Current @ Maximum Input Voltage	mA	18	18	23	30	18	18
Maximum Turn-On Time	mSec	0.20	0.050	0.050	0.025	0.20	0.20
Maximum Turn-Off Time	mSec	0.40	0.075	0.075	0.030	0.40	0.40
Nominal Input Resistance (Rx)	Ω	1.8K	1.8K	1.2K	500	1.8K	1.8K
Maximum Pick-Up Voltage (Output Low)	Vdc	3	3	2.5	2.5	3	3
Minimum Drop-Out Voltage (Output High)	Vdc	1	1	1	1	1	1
Nominal Logic Voltage (Vcc)	Vdc	5	5	5	5	15	24
Logic Voltage Range	Vdc	4.5-6	4.5-6	4.5-6	4.5-6	10-18	17-30
Max. Logic Supply Current @ Nominal Vcc	mA	10	18	10	18	10	10

OpenLine® Modules

Type/Function		Grayhill Part Number	
Dual, Polarized		70L-IDC	70L-IDCB
Specifications	Units		
Maximum Input Voltage	Vdc	32	32
Input Voltage Range ¹	Vdc	0-32	0-32
Input Current @ Max. Input Voltage	mA	18	18
Maximum Turn-on Time	mSec	0.20	0.05
Maximum Turn-off Time	mSec	0.40	0.075
Nominal Input Resistance (Rx)	Ω	1800	900
Maximum Pick-Up Voltage (Output Low)	Vdc	3	3
Minimum Drop-Out Voltage (Output High)	Vdc	0.9	0.9
Nominal Logic Voltage (Vcc)	Vdc	5	5
Logic Voltage Range	Vdc	4.5-28	4.5-28
Max. Logic Supply Current @ Nominal Vcc	mA	6/CH	6/CH
Module ID Resistance to Logic Ground	Ω	0	0

Available from your local Grayhill Distributor.
 For prices and discounts, contact a local Sales Office, an authorized local Distributor or Grayhill.

¹ For input voltages in the range of 90 to 140 Vdc, use AC input modules 70-IAC5, 70M-IAC5, 70G-IAC5 or 70L-IAC. For input voltages in the range of 180 to 280 Vdc, use AC input modules 70-IAC5A, 70M-IAC5A, 70G-IAC5A or 70L-IACA.