

Evaluation of Organic Coatings with Electrochemical Impedance Spectroscopy

Part 1: Fundamentals of Electrochemical Impedance Spectroscopy

David Loveday, Pete Peterson, and Bob Rodgers—Gamry Instruments*

INTRODUCTION

Beginning in the 1970s, research electrochemists and materials scientists began to discover the power of Electrochemical Impedance Spectroscopy (EIS) as a tool for studying difficult and complicated systems. Although this series of articles is aimed at the coatings scientist who is interested in EIS for coatings evaluation, EIS has application in virtually all areas of electrochemistry. This first article focuses on the general theory of EIS, and some of the instrumentation required to make the measurement. Subsequent articles will cover the challenges to making the measurement and the interpretation of EIS data on coated metal substrates. The final article will discuss the application of EIS to problems in coatings for corrosion protection.

THEORY

The concept of electrical resistance is well known and is defined by Ohm's law. Resistance is the ability of a circuit to resist the flow of current, mathematically expressed as

$$R = V/I \quad (1)$$

where r is resistance in ohms, V is voltage in volts, and I is current in amperes. However, this relationship is limited to one circuit element, the resistor. In the real world, many systems exhibit a much more complex behavior and we are forced to abandon the simple concept of resistance. In its place we use impedance, Z , which is a measure of a circuit's tendency to resist (or impede)

the flow of an alternating electrical current. The equivalent mathematical expression is

$$Z = V_{ac}/I_{ac} \quad (2)$$

This seemingly basic equation actually hides some sophisticated assumptions and concepts. First, it applies only to the time varying, alternating, or ac, components of the current and voltage. Secondly, it is not sufficient to just tell how big the voltage and current signals are, we must also say how they are related in time, since they are both time-varying, ac quantities. Finally, the size- and time-relationships nearly always depend on the frequency of the alternating current and voltage.

Figure 1 shows a sine wave voltage applied to an electrochemical cell. The current response is also shown. It is a sine wave, but it is shifted in time due to the slow response of this system. We may express this time shift as an angle—the phase angle shift of the current response, or simply the phase angle, Θ . If one cycle (360°) of the sine wave takes 1 sec, and the time shift between the current and voltage sine waves is 0.1 sec, then the phase angle is 36° .

The size of the impedance of this system can be expressed by taking

the ratio of the size of the voltage sine wave (in volts) to that of the current sine wave (in amperes). This gives us the *magnitude*, or size, of the impedance (in ohms) of this system. You may see it written as $|Z|$. The magnitude of the impedance ($|Z|$) is sometimes called the *modulus* of the impedance. To characterize an impedance, Z , you must specify both its magnitude, $|Z|$, and phase, Θ , as well as the frequency, f (in cycles per second, or Hertz), at which it was measured. These three parameters are often plotted on what is known as a Bode plot, shown in Figure 2A. Because the frequency can range from 100,000 Hz to 0.001 Hz or less, the frequency axis (the x-axis) is plotted logarithmically. Since $|Z|$ can also change by a factor of a million or more in a simple experiment, the $|Z|$ -axis is also plotted on a log axis. Bode plots are often used to display EIS data.

Figure 1—Current and voltage as a function of time. Note the time shift between them.

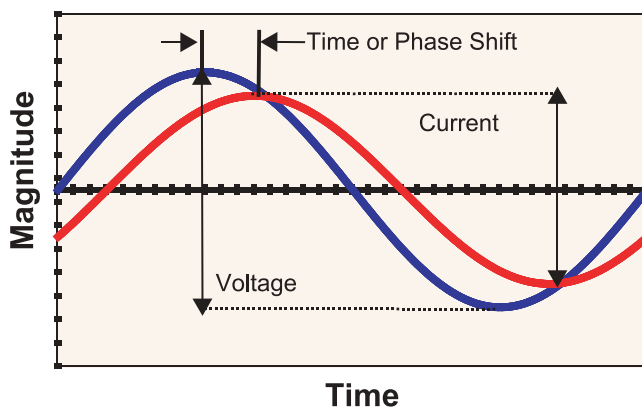

*734 Louis Dr., Warminster, PA 18974; Voice: 215.682.9330; Fax: 215.682.9331; Email: broddgers@gamry.com.

Figure 2—Bode plot, magnitude and phase (A, left) and Nyquist plot (B, right).

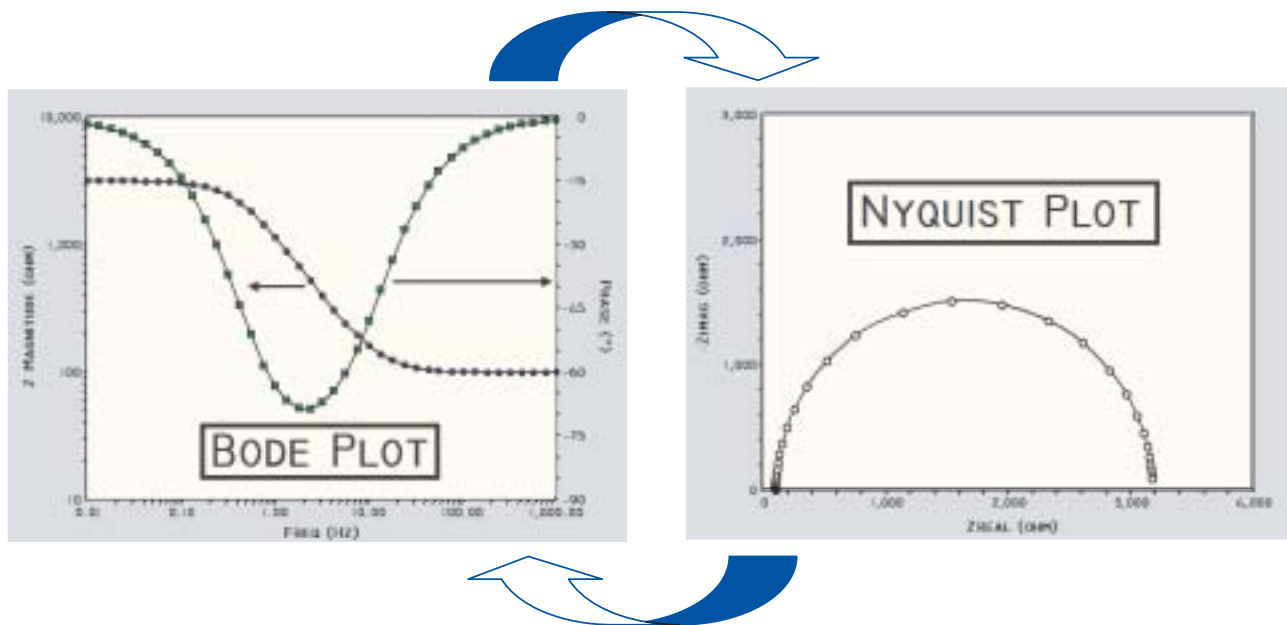

The $|Z|$ and Θ information from the Bode plot can also be displayed in polar form as a vector, as shown in *Figure 3A*. The length of the vector is $|Z|$ and the rotation of the vector is the phase angle, Θ . The position of the end of the vector can also be expressed in Cartesian coordinates as shown in *Figure 3B*. The point in the plane can be identified either as $(|Z|, \Theta)$ in the polar coordinates or as (X, Y) in the Cartesian coordinates. If we re-labeled the axes as Real (X axis) and Imaginary (Y axis), the point in the Complex Plane expressed as (X, Y) or (Real, Imaginary) can then be written as a complex number

$$Z = X + j Y \text{ where } j = \sqrt{-1}. \quad (3)$$

The “complex” or “imaginary” number (j) is a mathematical way of expressing and manipulating the impedance vector. The value of the “real” part of the impedance (X) is often written as Z_{re} or Z' while the “imaginary” part of the impedance (Y) is written as Z_{im} or Z'' . The magnitude of a complex number (or the magnitude of an impedance) can be easily calculated by

$$\sqrt{(Z_{re}^2 + Z_{im}^2)} = Z_{\text{magnitude}} = |Z| \quad (4)$$

When the impedance is measured at a number of frequencies and is plotted on the Cartesian axes, the resulting plot is called a Nyquist plot. It is sometimes

referred to as a Cole-Cole plot or a Complex Plane plot. The frequency never explicitly appears on a Nyquist plot; it must be obtained from the raw data point. The data from the Bode plot in *Figure 2A* is shown as a Nyquist (or Complex Plane) plot in *Figure 2B*. It is exactly the same data; it is just plotted in a different format.

Both plotting formats are used because each has its strengths. Subtle features that are difficult to identify in the Nyquist plot may be readily apparent in the Bode plot, and vice versa. The Bode plot shows the frequency directly and small impedances are identifiable in the presence of large impedances. The Nyquist plot also allows individual impedances to be resolved, but the frequency is not explicitly shown. Small impedances in a Nyquist plot may be difficult to identify in the presence of large impedances.

SIMPLE EQUIVALENT CIRCUITS

Electrochemical systems such as coated surfaces or corroding metals of-

ten behave like simple electronic circuits. Within the framework of ac waveforms, we can examine a few simple circuit elements and a simple, but useful, combination of them.

The simple resistor was discussed earlier in terms of Ohm’s law. If a sine wave voltage is applied across a resistor, the current will also be a sine wave. The current through a resistor reacts instantaneously to any change in the voltage applied across the resistor. The current sine wave is exactly in phase with the voltage sine wave. There is no time lag. The phase angle of a resistor’s impedance ($Z = V_{ac}/I_{ac}$) is 0° because the current sine wave is exactly in phase with the voltage sine wave. For an ideal resistor, this is true at all frequencies. Also,

Figure 3—Vector representation (A, polar coordinates, left) and Complex Plane representation (B, Cartesian coordinates, right) both specify the same point.

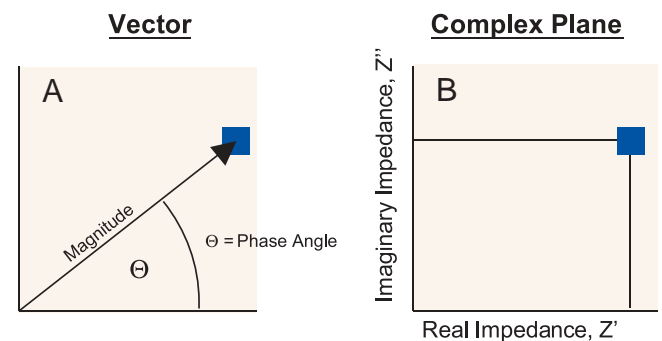
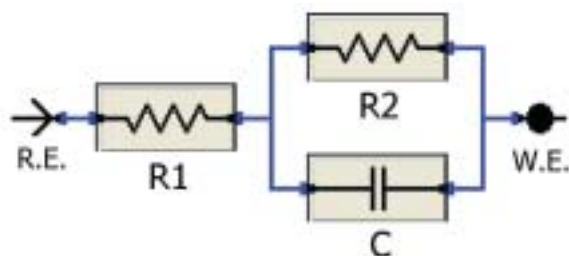

Figure 4—The Randles cell equivalent circuit.



the amplitude of the current sine wave does not depend upon the frequency; it depends only on the Resistance R (in ohms) and the amplitude of the voltage sine wave. The impedance of a resistor is easy to write as a complex number. Since the phase angle is always 0, the end of the "vector" in Figure 3 always lies on the X, or real axis. The Y (imaginary) component is always zero.

$$\begin{aligned} Z_{\text{resistor}} &= Z_{\text{re}} + j Z_{\text{im}} & (5) \\ &= R + j 0 \\ &= R \end{aligned}$$

The Bode plot for a resistor is quite simple. Since the impedance of a resistor is independent of frequency, the Bode magnitude plot is just a horizontal straight line. The Bode phase plot is just as unremarkable; the phase is always zero.

An example of a resistance in electrochemistry is the resistance of the electrolyte in the electrochemical cell. The resistance of a column of electrolyte, or of a wire, can be calculated from the length of the column or wire, L , the cross-sectional area, A , and the resistivity of the electrolyte or wire material, ρ , in ohm-cm:

$$R = \rho L / A \quad (6)$$

The capacitor is another simple, yet useful, electronic circuit element. Sandwiching a piece of nonconducting plastic (called a dielectric) between two metallic conducting plates makes a capacitor. For a capacitor, the current is 90° out-of-phase with the voltage. A sine wave voltage waveform leads to a cosine current waveform. The current reaches a maximum when the voltage is changing the fastest, as it crosses through zero. The magnitude of the current also depends on frequency. The higher the frequency, the more rapidly the voltage changes, and the higher is

the magnitude of the current. Since $Z = V / I$, a larger current at higher frequencies leads to a smaller impedance. At zero frequency (dc), the current is zero since there is a nonconductor between the plates. As you approach zero frequency, current approaches zero and the impedance, Z , becomes infinitely large. The impedance of a capacitor can be expressed as

$$\begin{aligned} Z_{\text{capacitor}} &= Z_{\text{re}} + j Z_{\text{im}} & (7) \\ &= 0 + j [-1 / (2 \pi f C)] \\ &= j [-1 / (2 \pi f C)] \end{aligned}$$

Because the impedance of a capacitor varies with the inverse of the frequency ($1/f$, or f^{-1}), the Bode magnitude plot for a capacitor is a straight line with a slope of -1. Because the phase shift of a capacitor is always 90°, the Bode phase plot is a horizontal line at -90°.

An example of a capacitor is a metal coated with an impervious coating, immersed in an electrolyte. The metal substrate forms one plate of the capacitor. The conducting electrolyte solution forms the other "plate." The impervious coating separating the two is the dielectric of the capacitor. Another example, in electrochemical terms, is the double-layer capacitance of a metal in an electrolyte solution. Again, the metal electrode is one plate of the capacitor; the conducting electrolyte is the other. In this case, though, the dielectric is a very thin layer of water, just one or two molecules thick, which separates the two plates.

The capacitance can be calculated from the dimensions of the capacitor, and the nature of the material separating the plates.

$$C = (\epsilon)(\epsilon_0)(A) / t \quad (8)$$

C is the capacitance in farads, A is the plate area, ϵ is the dielectric constant of material separating the plates, and t is the thickness of the material; ϵ_0 is 8.85×10^{-14} farads/cm. Because the electrical double layer's dielectric is so thin, the double-layer capacitance can be quite high: 10 to 100 $\mu\text{F}/\text{cm}^2$. Because a coating is quite thick by comparison (perhaps 50 μm), the capacitance of a coating will be 0.001 $\mu\text{F}/\text{cm}^2$ or 1 nF/cm².

THE RANDLES CELL

The Randles cell is a simple, yet useful combination of a capacitor and two resistors (Figure 4). This electrical circuit can be used to represent a coating or a corroding metal, although the values and meanings of the components are different. Our use of this electrical equivalent circuit does not require that our physical electrochemical system be made of physical resistors and capacitors. What is really meant is that this simple circuit, which can be built from parts available in an electronics shop, and the electrochemical system, built from electrodes and electrolytes, both behave in the same manner when an alternating voltage is applied. The equivalent circuit model can provide us with a simple way of understanding what may be a complicated electrochemical system. In using this model, we should try to associate a real, physical process with each of the circuit components in the model.

When this equivalent circuit model is applied to a coating immersed in an electrolyte, $R1$ represents the resistance of the electrolyte solution between the reference electrode tip and the surface of the coating. This is often called the uncompensated resistance (R_u). It is generally only a few ohms if the electrolyte's salt concentration is a few percent. The capacitor, C , represents the coating and can be characterized by the thickness and dielectric constant of the coating material. It is typically about 1 nF/cm². We associate the resistor, $R2$, with the resistance of the coating. It is also a property of the material of the coating and varies with the thickness and composition of the coating. Coating resistances can be quite high, greater than 10^{10} ohm-cm², for a good epoxy coating.

The same equivalent circuit can also be applied to a bare, corroding metal in an electrolyte solution. Once again, $R1$ is associated with the electrolyte resistance. However, in this system, the capacitor, C , is associated with the double layer capacitance (C_{dl}) of the metal/electrolyte interface. It is generally between 10 and 100 $\mu\text{F}/\text{cm}^2$. In this application, the resistor $R2$ is the Polarization Resistance, R_p . This association can only be made under certain conditions, however. We know from electrochemical theory (Bard and Faulkner, 2000) or Butler-Volmer kinetics (Jones, 1995), that the real current-

voltage relationship is a nonlinear one. However, if we limit the ac voltage excursions to only a few mV, the curvature of the current-voltage curve will not be too great, and we may approximate the true relationship with a straight-line, linear approximation. In general, EIS measurements are made with an ac amplitude of 10 mV or less. In rare circumstances, larger voltages can be applied, but with care.

It is instructive to look at the frequency dependence of the impedance of the simple Randles cell as it is displayed on a Bode plot and on a Nyquist plot (Figure 5). Recall that a resistor's impedance does not change with frequency and that a capacitor's impedance is inversely proportional to the frequency. At very low frequency the impedance of a capacitor is nearly infinite. The capacitance acts as if it were not there; it acts like an open circuit. Only the two resistors remain. The resistors are in series, which means that all of the current that passes through R1 also passes through R2. The combination of the two looks like a single, longer resistor with a higher resistance value. The effective impedance of two resistors in series is just the sum of the two individual resistance values. On the Bode plot the magnitude should be $(R1 + R2)$ and the line should be horizontal. The phase angle should also be 0° , as we expect for a pure resistance. We see this "resistive" behavior at the low frequency (left) side of the Bode plot.

At high frequency, the impedance also shows resistive behavior, but for a different reason. As the frequency increases, the impedance of a capacitor becomes ever smaller [See equation (7)]. At some frequency the impedance of the capacitor is so much smaller than R2 that all the current flows through the capacitor and none flows through R2. At the limit of high frequency, the capacitor acts as if it were a short circuit or as a zero ohm impedance or as a piece of wire. The impedance, then, is only the impedance of R1. This leads to the resistive behavior at the high frequency (right) end of the Bode plot.

At intermediate frequencies, the capacitor cannot be ignored. It contributes strongly to the overall magnitude of the impedance. The impedance will be between R1 (high frequency limit) and $R1+R2$ (the low frequency limit). At both very high and very low

Figure 5—Bode plot (top) and Nyquist plot (bottom) for the Randles cell (center).

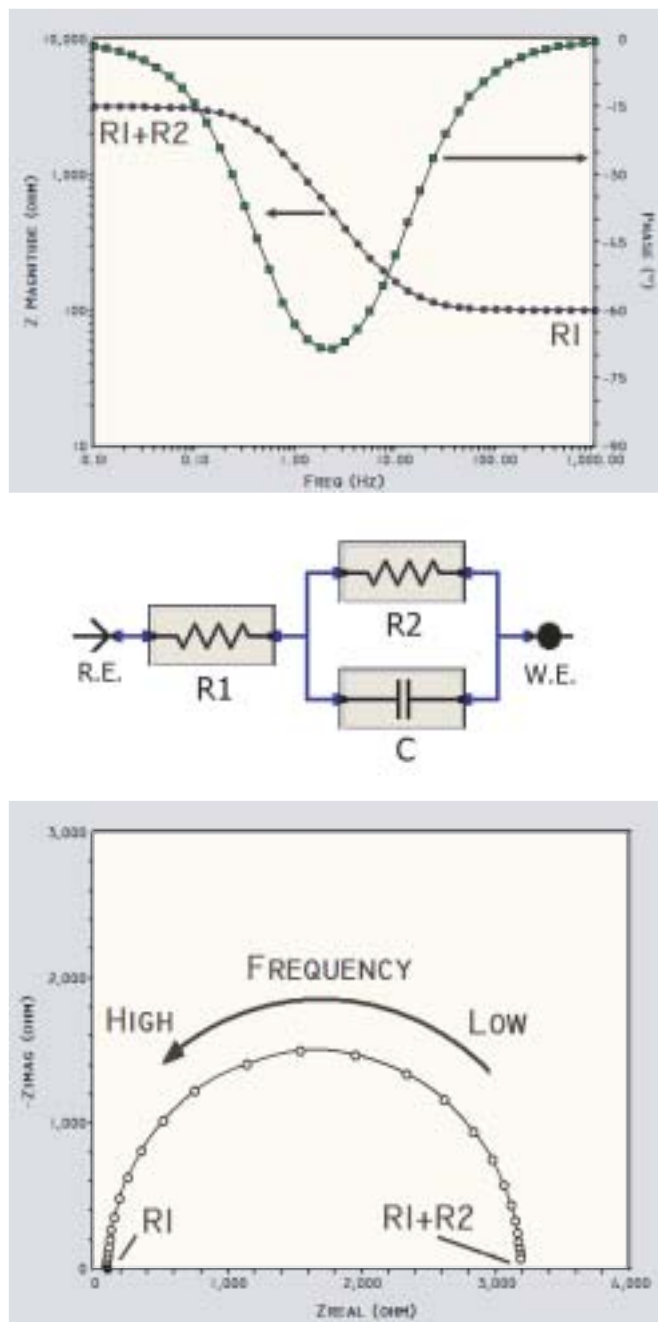

frequencies, the phase is nearly zero. However, at intermediate frequencies the phase angle starts to approach -90° , the phase angle for a capacitor. In this region, the slope is often (but not always) close to the -1 slope we expect for a capacitor.

The Nyquist Plot for the Randles cell is another way of looking at the same trends that have been seen on the Bode plot. At both high and low frequencies

the impedance plotted on a Nyquist plot lie on the X- or real-axis. Since the impedance at high frequency is smaller than that at low frequency, it is important to note that the high frequency end of the semicircle ($|Z| = R1$) shown in the Figure 5 is on the left and the low frequency end ($|Z| = R1 + R$) is on the right. At intermediate frequencies the real (X) component is between these two extremes.

Figure 6—A simple electrochemical cell for making EIS measurements on coatings.

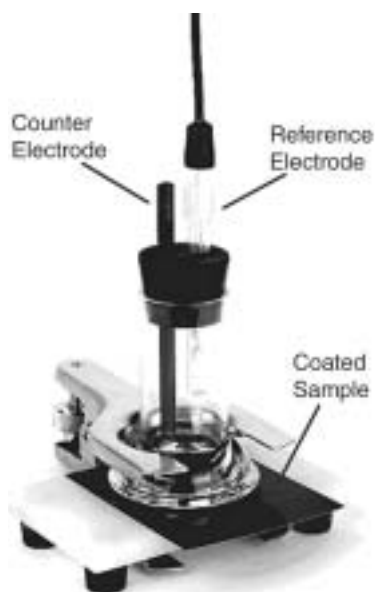

ACQUIRING THE DATA: CELL AND INSTRUMENTATION

Figure 6 shows a typical cell for making impedance measurements. The cell is constructed in the same manner used in everyday electrochemical measurements, such as for studying corrosion. A sample electrode (working electrode), a reference electrode, and a counter electrode are immersed in an electrolyte solution (for instance, 5% NaCl in water). The reference electrode is typically a saturated calomel electrode (SCE) and the counter electrode is usually an inert material like a platinum mesh or a carbon rod. There may be a provision for stirring and for removing oxygen from the electrolyte.

The instrumentation (Figure 7) required includes a waveform generator to produce the sine waves and potentiostat to control the potential. It must control both the dc potential as well as the added ac excitation voltage. The instrumentation must also contain a means of accurately measuring the ac components of both the voltage and the current and the phase relationship between them. This data is used to calculate the impedance of the system. Because of the complexity of optimizing and coordinating these ac measurements, a computer is generally used to run the experiment and to display the results in real time.

Over the years, various technologies have been used to measure the current and voltage amplitudes and the phase relationship between them. Early measurements were done manually using an oscilloscope or an impedance bridge. Today, the measurements are computerized and the ac components may be measured with a frequency response analyzer, with a lock-in amplifier, by using Sub-Harmonic Sampling, or by using a Fourier transform technique. All of these methods are capable of measuring the impedance with suitable accuracy. In a practical sense, more errors may be introduced by the potentiostat.

The data collected by the computer program should include the frequency of the ac waveform and either the magnitude and phase of the impedance at each frequency, or the real and imaginary components of the impedance, or perhaps both. Most modern programs allow the display of either or both of these equivalent display formats, the Bode plot or the Nyquist plot. Other parameters, such as the dc current and dc voltage are often recorded as well, and can be useful in interpreting the data in some of the more complicated systems. This additional information is often not needed, however.

A small (5–10 mV) amplitude ac signal is applied to the sample by the potentiostat and the current response is analyzed to extract the phase and amplitude relationship between the current and the voltage signals. In some coatings applications, larger signals can be applied, but care must be taken to insure that the system is linear over the ac

voltage range. In studying bare metal corrosion, larger amplitudes are almost never used.

Because the potentiostat controls and measures the voltage difference between the reference and working electrodes (Figure 7), only the impedance between these two electrodes is measured. The impedance at the counter electrode and the resistance through the bulk of the solution is not sensed when a three-electrode potentiostat is used.

The number of cycles used to collect the data determines the precision of the measurement. At low frequencies, the trade-off between the length of the experiment and precision is a serious consideration. A single cycle of a 0.001 Hz sine wave takes 17 min. Although sampling many cycles would improve the precision of the measurement, to do so would lengthen the experiment and increase the chances that the sample changes during the experiment. The theory of EIS requires that the system be stable and unchanging as well as linear. Unfortunately, for some extremely impervious, high impedance coatings, data must be taken at low frequencies, sometimes even lower than 0.001 Hz. To be fair, however, even a slow, 0.00001 Hz (27 hr per cycle) experiment which will take days to complete is faster than waiting months or years for an exposure test to be completed.

The impedance is usually measured as a function of frequency over many decades, for example from 100 kHz to 0.001 Hz. For this reason the measurement points are chosen logarithmically to get an even spread of points across

Figure 7—A block diagram of the modern instrumentation used to make the EIS measurement. Often, more than one of these functional blocks are included in a single instrument, or even inside the computer.

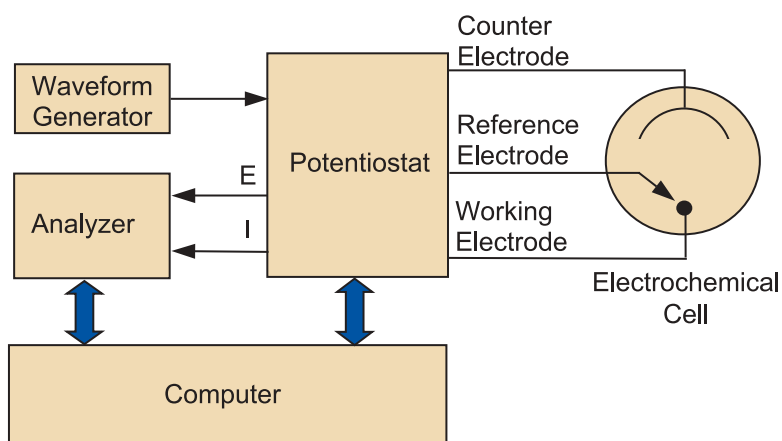
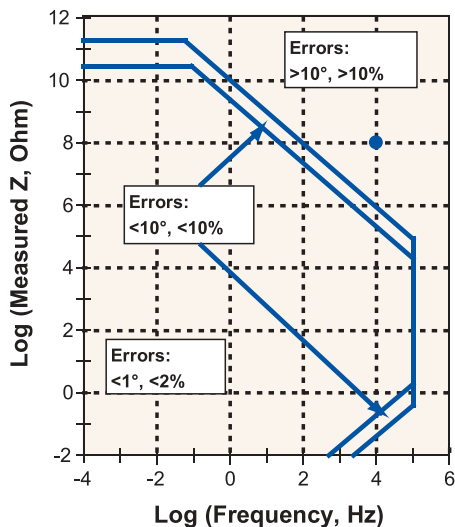

Figure 8—This Bode plot shows the likely errors in the measured impedance for a given frequency for a commercial potentiostat.



the whole frequency range. This gives the high frequency data an equal weight with low frequency data.

Making EIS measurements at very high or at very low impedances, or at very high frequencies, is a difficult task. At any of these extremes you may be able to make the measurement, but it may not be a meaningful or useful one. At both very high impedances and at very low impedances, you may be measuring the characteristics of your cell geometry, or of the wiring, or of your potentiostat, and not the characteristics of your coating or corrosion reaction. Many, but not all, potentiostat manufacturers will specify the impedance and frequency limits for making reliable and accurate measurements that reflect the sample you are trying to study. It is important to be aware of the limits. *Figure 8* shows how the errors in the impedance depend on the frequency and on the impedance. For example, consider measuring a sample with a 10^8 ohm impedance at 10 kHz (10^4 Hz). Although the measurement may be possible with this potentiostat, *Figure 8* indicates that the errors will be greater than $10^\circ/10\%$. The errors will be significantly greater since the impedance/frequency point is far from the dividing line.

OPEN LEAD CURVE

Fortunately, there is quick and simple way to test the sensitivity of an EIS

Figure 9—The “Open Lead” curve for a commercial potentiostat. Also shown is the manufacturer’s estimation of the highest impedance that can be measured with a 1% error or less.

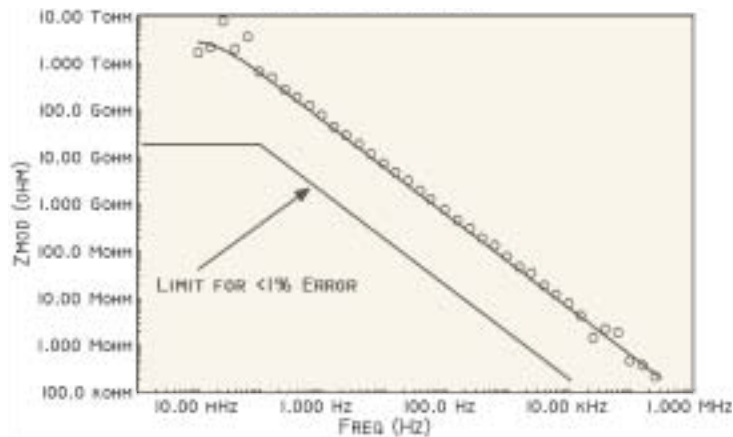
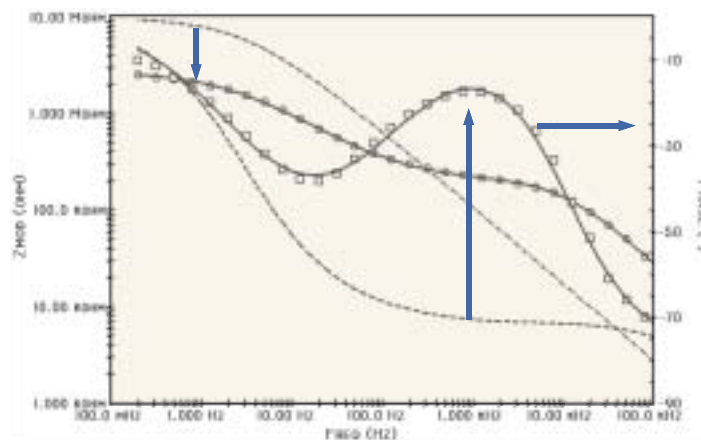

Figure 10—A fit to a more complicated model. The curve for the initial estimates for the parameters is also shown.



system. To determine the maximum impedance that can be measured with a particular EIS instrument, run an EIS curve with no cell attached to the instrument. The reference and counter electrode leads must be connected together. If a “sense,” “working sense,” or “RE2” lead is provided on your potentiostat, it must be connected to the working electrode lead. All of the cell leads should be placed in a grounded Faraday Cage. Impedances higher than the Open Lead impedance cannot be measured. The Open Lead Curve of a commercial potentiostat is shown in *Figure 9*. The impedance at 10 kHz is about 10 Mohm (10^7 ohm). Therefore, at 10 kHz, the highest sample impedance that can be measured with this instru-

ment is 10^7 ohm. However, there will be substantial error in the measurement. At 0.1 Hz, this instrument can measure, at most, 10^{12} ohm. To be sure that the measured impedance has less than a few percent error in the magnitude, or less than a few degrees error in phase, the impedance must be 50 to 100 times lower than the limits estimated from this “Open Lead” experiment. At 0.1 Hz, then, the maximum impedance that can be measured with acceptable accuracy is 10^{10} – 10^{11} ohm.

A similar estimation of the limits of error at low impedances can also be made. In this case, all of the potentiostat leads are nominally shorted together. This is not as easy an experiment to do. Fortunately, sub-ohm imped-



A computerized electrochemistry instrument with an Electrochemical Impedance Spectroscopy plot. The actual electrochemical instrument is draped over the keyboard.

ances will not be encountered in the coatings laboratory, and details of that experiment will not be covered here.

DATA ANALYSIS AND INTERPRETATION

Once data has been collected, the next step is to analyze the results. Several methods can be used. Some of these will be described in Part 2 of this series. Some of the analysis techniques rely upon the measurement of the impedance or phase angle at a single frequency. These can be used in a QC or QA setting, but only after there is a deeper understanding of the actual mode of coating degradation or failure.

It is tempting to say that you should explain your impedance data based upon a physio-chemical model derived from first principles. Although this makes an excellent treatise, few of us have the luxury of time to complete this task.

A more commonly applied approach is to create an equivalent circuit model. This approach makes the analogy between the processes in the electrochemical cell and electrical circuit components such as resistors and capacitors.

This is a very useful technique, but must be applied with some caution. It is not sufficient to create a model that fits your EIS data without also showing the relationship between the circuit elements you have used in your circuit model, and physical- or chemical-processes that occur in your coating.

Most of the models begin with Randles cell that we have discussed. A nonlinear least squares technique is generally used to determine the values of the circuit elements (resistors and capacitors) that best fit the EIS data taken on the coating. Because the mathematics becomes complicated when even two or three circuit elements are used, the optimum values generally cannot be computed analytically or in closed form. An iterative approach is used. It begins with a rough estimate for the circuit element parameters and then refines that guess until the best fit is obtained (see Figure 10). Fitting programs are available from several sources. Nearly all require that the user select a suitable model and provide the first guess of the circuit parameter values. A library of models is generally available, along with the capability of designing your own model. The resistor and capacitor discussed in this article are only

the tip of the iceberg. Many other special purpose circuit elements have been invented by the electrochemist to model other processes. Examples are diffusion (the Warburg impedance), or a chemical reaction that precedes the electron transfer (the Gerischer impedance).

SUMMARY

EIS is a general purpose electrochemical technique applicable to virtually all areas of electrochemistry. In this article, we have covered the basics of electrochemical impedance spectroscopy: the theory behind the measurements, the equipment and cells required for painted samples, how to use them, and an introduction to equivalent circuit modeling of the collected data.

The next article in the series will focus on the physical description of a coating on a metal surface, how that relates to circuit elements for data fitting, the experimental pitfalls, and, finally, analysis of the different stages of coatings degradation. In the final article, we will discuss how coatings scientists use the various methods available to get an understanding of failures modes of coatings.

BIBLIOGRAPHY

Macdonald, J.R., *Impedance Spectroscopy; Emphasizing Solid Materials and Systems*, Wiley Interscience, 1987.

Bard, A.J. and Faulkner, L.R., *Electrochemical Methods; Fundamentals and Applications*, Wiley Interscience, 2000.

Jones, D.A., *Principles and Prevention of Corrosion*, Prentice Hall, 1995.

Scully, J.R., Silverman, D.C., and Kendig, M.W. (Ed.), *Electrochemical Impedance: Analysis and Interpretation*, ASTM, West Conshohocken, PA, 1993.

Cottis, R. and Turgoose, S., *Electrochemical Impedance and Noise*, NACE International, Houston, TX, 1999.