

We offer the widest range of high-speed digitizers and instrumentation cards available on the market today. Our powerful PC-based instrumentation products allow you to create reliable, flexible and high-performance solutions quickly and easily.

Reduce development time and costs for testing complex applications such as radar, wireless communications, spectroscopy, etc. by using our Windows-based application software or our SDKs.

## APPLICATIONS

Testing of electronic devices and sub-systems  
Bus monitoring and testing  
Manufacturing test  
Synthetic instrumentation

## CompuScope 3200

**32 bit, 100 MHz digital input card for the PCI bus**



Fast and versatile digital capture card with logic analyzer characteristics for electronic test applications.

## FEATURES

- Capture 32 bits of digital data
- 100 MHz clock rates
- Deep on-board buffers of up to 2 GigaBytes
- Multi-card systems providing wider input words of up to 256 bits
- Free GageBit software allows creating and editing of digital patterns
- Software Development Kits available for LabVIEW, MATLAB, C/C#, LabWindows/CVI

## CompuScope 3200 Simplified Block Diagram

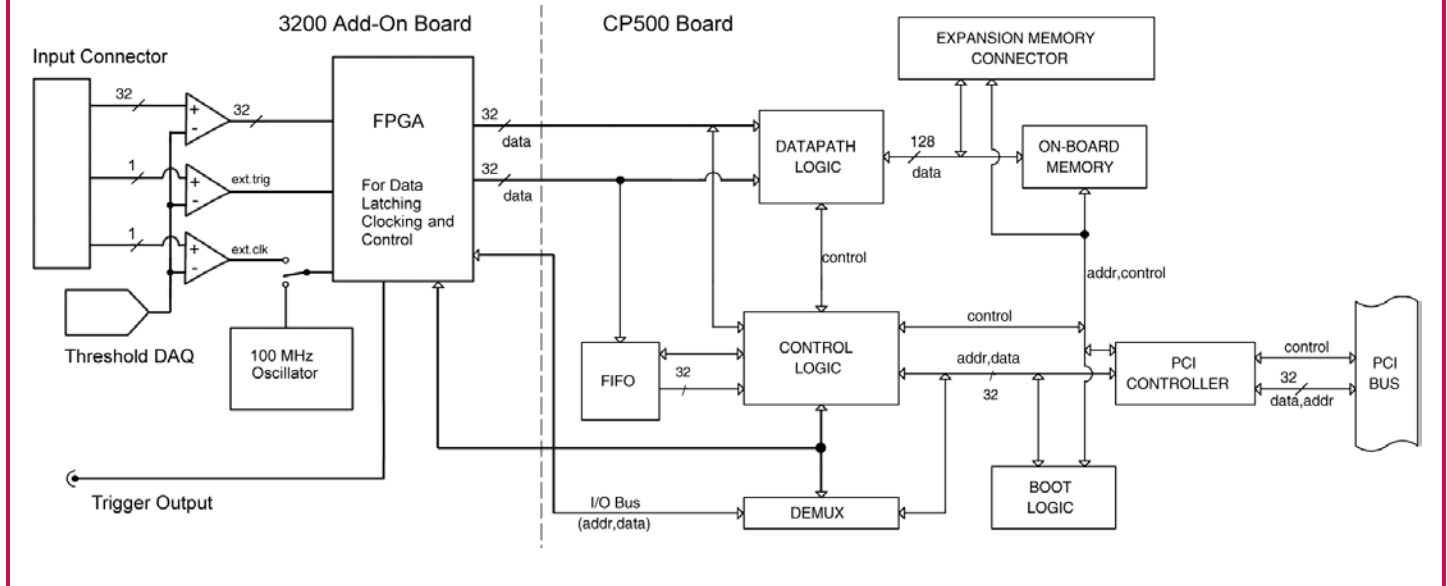

### COMPUSCOPE 3200

The CS3200 is a PCI bus based product which allows the user to capture up to 32 bits of CMOS or ECL digital data into on-board memory at clock rates up to 100 MHz. The inputs can be set at the factory to be either differential or single-ended.

The CS3200 can also be configured, in software, to be either 8, 16 or 32 bits wide, thereby allowing the user to maximize the use of storage memory for 8 or 16 bit inputs.

Multiple CS3200 boards can be used in Master/Slave configuration to provide wider input words of 64, 96 or 128 bits.

### INPUT CIRCUITRY

The input stage of the CS3200 consists of 34 high speed comparators: 32 for data and one each for clock and trigger. The use of high speed comparators with fully programmable thresholds allows the use of virtually any logic level: 5 Volt TTL/CMOS, 3.3 V CMOS, 2.7 V CMOS, ECL, PECL or even custom logic levels.

In order to avoid signal reflections, all CS3200s are terminated by a 50 Ohm resistor. Consequently, inputs need to be driven by a source capable of driving a 50 Ohm load. This is necessary in order to maintain good signal integrity.

For CMOS or TTL signal sources not capable of driving 50 Ohm loads, a special CMOS Buffer Board is available from Gage which buffers the data with 50 Ohm line drivers. The input of the Buffer Board is a 68 pin IDC header for data, a BNC connector for Trigger and another BNC for Clock input. All signals must be 0 to 3.3 V or 0 to 5V CMOS or TTL signals.

The output of the CMOS Buffer Board is a 68 pin MDR connector which connects to the CS3200 using a 6 foot long pleated foil cable, supplied with the CS3200.

Differential ECL or PECL signals are, by definition, capable of driving a 50 Ohm load and interface seamlessly with the CS3200.

### CONFIGURABLE INPUT

The output of the on-board comparators is fed into an on-board FPGA which demultiplexes the data from 8, 16 or 32 bits to the 64 bit width required by CP500 board under software control.

The presence of this FPGA also makes it possible to build customized digital acquisition systems, including front-end data processing, for specific requirements. Contact the factory for such custom applications.

The only choice customers must make at the time of placing the order is whether they require a differential input or single-ended input CS3200. This setting must be configured at the factory and cannot be modified in the field.

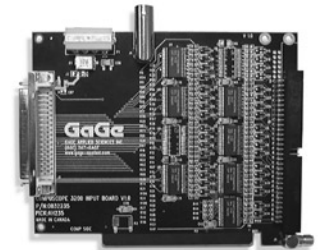

### ON-BOARD MEMORY

The CS3200 stores digital data in on-board memory which is addressable through the PCI bus under software control.

The memory on-board a CS3200 consists of high-speed Static RAM whose default size is 2 MB. Models with 8 MB, 16MB, 128MB, 512MB, 1GB and 2GB are also available.

The on-board memory is configured as a circular buffer, so it is possible to store both pre and post trigger data. In other words, it is possible to wait indefinitely for a trigger event and then capture digital data from both before and after this event.

The amount of data words which can be captured into on-board memory is a function of the size of the memory and input width. For example, a 16 MB model provides 16 million words of storage when the input is 8 bits wide. The same model can only provide 4 million samples of memory with 32 bit word width.

## MEMORY MODE

Memory mode is the standard mode of operation of the CS3200. In this mode, data is stored in the very deep on-board memory buffers. A maximum throughput of 400 MB/s can be maintained in this mode.

## TRANSFERRING DATA TO PC MEMORY

The CS3200 is fully capable of acting as a bus master to DMA captured data into user buffers.

Scatter-Gather DMA is also supported in the Windows environment, making it possible to manipulate data in a Windows program without having to create special, physically contiguous buffers combined with slow memcopy commands.

## EXTERNAL CLOCK

The CS3200 allows the use of either internal or external clocks. External clock can be very useful in systems which require synchronous data capture. These applications include A/D Testing, Telecommunication, DSP Systems, Video, Ultrasonic Imaging, etc.

The external clock is carried on the 68 wire input connector. A high speed comparator converts the input level of the clock to CMOS/TTL levels used by the on-board data latching and demultiplexing circuitry.

The maximum frequency of the input clock is 100 MHz. The driving circuitry on the user's circuit must be capable of driving a 50 Ω load.

## CLOCK EDGE SELECTION

The user is able to select either the rising or falling edge of the input clock to latch the data.

This flexibility allows the user to apply the CS3200 in situations in which one of the clock edges and input data do not satisfy the timing requirements. In such cases, using the opposite edge of the clock may resolve the timing conflict.

## CLOCK AND DATA TIMING

If the customer operates the CS3200 with an external clock, it should be kept in mind that the maximum speed of the input clock is 100 MHz. The minimum clock frequency is zero, i.e. the clocks can be started and stopped at will, as long as the clocks are being supplied during initialization and arming of the CS3200.

The setup and hold times of the data with respect to the active edge of the clock must satisfy the minimum requirements listed in figure 1 below.

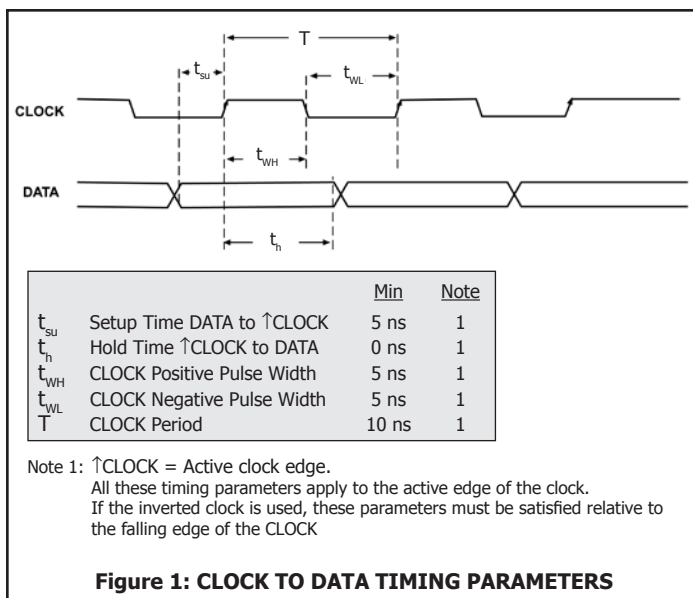

## CRYSTAL BASED TIMEBASE

The CS3200 allows the use of both Internal or External clock under software control.

When the internal clock is selected, the sampling clock is provided by a crystal controlled oscillator, thereby providing very good short and long term timing accuracy.

When an external clock is used, the timing accuracy depends entirely on the quality of the external clock supplied by the user.

## INPUT CONNECTOR

The data is input to the CS3200 over a 68 wire Pleated Foil cable. The input connector is a 68 pin MDR socket (P/N 3M 0268-55H3VC). The mating connector is a 3M 10168-6000EC.

The Mating connector hood is a 3M 10368-A230-00.

Each CS3200 is supplied with a 6 foot Pleated Foil cable featuring the 3M 10168-6000EC connector.



## TRIGGER

A trigger input is provided on the CS3200. The configuration of this input is set at the factory as either differential or single-ended.

It is possible to trigger either on the rising or falling edge of this trigger input.

In Normal mode, both pre and post trigger data are captured into on-board memory. In Multiple Recording mode, only post trigger data is stored in on-board memory.

For timing information on trigger input with respect to clock, please see Figure 2.

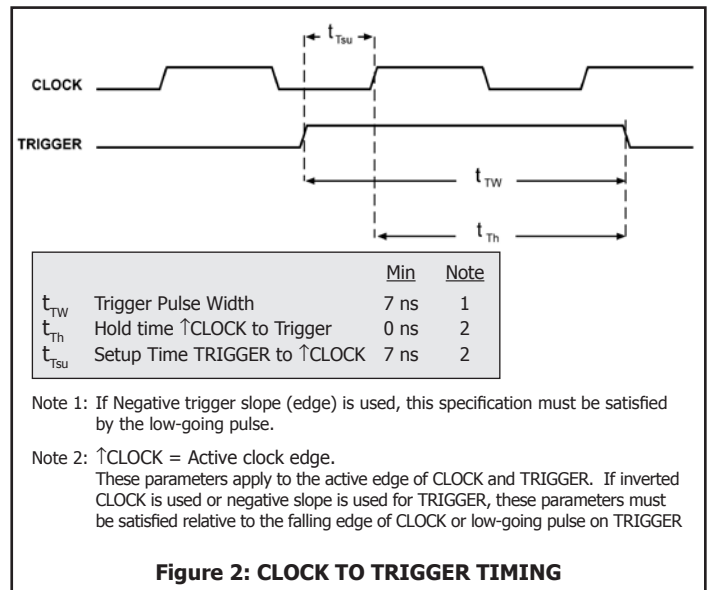

## TRIGGER OUTPUT

A Trigger Output signal is also provided by the CS3200. This signal is synchronized to the internal clock which runs the demultiplexed memory counters. As such, there can be a latency of as much as 8 clock cycles between a trigger input and a trigger output.

This Trigger Output can be used to synchronize an entire system to Gage's internal clock.

## Pin Layout on CS3200 Connector

Single-Ended (Differential)

1	CLK +	35	GND (CLK -)
2	D0 +	36	GND (D0 -)
3	D1	37	GND (D0 -)
4	D2	38	GND (D0 -)
5	D3	39	GND (D0 -)
6	D4	40	GND (D0 -)
7	D5	41	GND (D0 -)
8	D6	42	GND (D0 -)
9	D7	43	GND (D0 -)
10	D8	44	GND (D0 -)
11	D9	45	GND (D0 -)
12	D10	46	GND (D0 -)
13	D11	47	GND (D0 -)
14	D12	48	GND (D0 -)
15	D13	49	GND (D0 -)
16	D14	50	GND (D0 -)
17	D15	51	GND (D0 -)
18	D16	52	GND (D0 -)
19	D17	53	GND (D0 -)
20	D18	54	GND (D0 -)
21	D19	55	GND (D0 -)
22	D20	56	GND (D0 -)
23	D21	57	GND (D0 -)
24	D22	58	GND (D0 -)
25	D23	59	GND (D0 -)
26	D24	60	GND (D0 -)
27	D25	61	GND (D0 -)
28	D26	62	GND (D0 -)
29	D27	63	GND (D0 -)
30	D28	64	GND (D0 -)
31	D29	65	GND (D0 -)
32	D30	66	GND (D0 -)
33	D31	67	GND (D0 -)
34	TRIG IN +	68	GND (TRIG -)

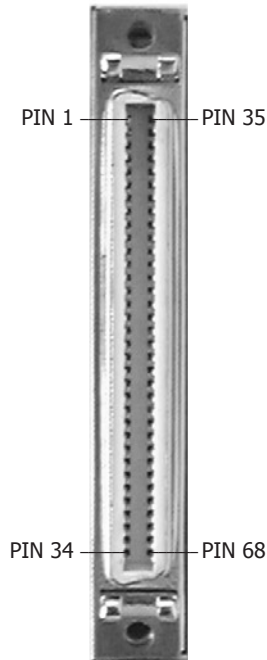

## SLOT USAGE

CS3200 boards occupy one full-length PCI slot for the standard 2MB memory depth, two slots for the 8MB and 16MB memory depths and 3 slots for 128MB, 512MB, 1GB and 2GB memory versions.

It is important to note that the CS3200 is a full length PCI board and requires proper mechanical clearance in the computer chassis.

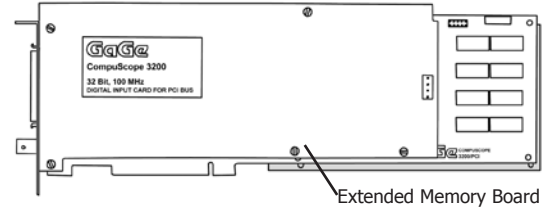

The Extended Memory Board for the 8 and 16 M versions of CS3200 take up the space of two slots. Higher memory versions occupy the space of 3 slots. Contact Factory for 2-slot deep memory solution.

## SOFTWARE SUPPORT

The CS3200 operates under GageBit -- Gage's Digital Input/Output Software for Windows. GageBit allows the CS3200 to be operated in all available operating modes. Captured digital samples can be displayed graphically, with each bit plotted as a function of time. Digital samples can also be displayed in a list box as decimal, hexadecimal or binary representations. Data can also be logically manipulated and stored to file.

GageBit also supports the CompuGen 3250, the natural complement to the CS3200. GageBit is able to generate a digital pattern with the CG3250, capture data with the CS3200 and compare the results.

The CS3200 is also supported by all CompuScope SDKs, each of which include specific digital input sample programs illustrating the use of the CS3200.

## SYSTEM REQUIREMENTS

PCI-based computer with at least one free full-length PCI slot, 128 MB RAM, 50 MB hard disk and SVGA video.

## SIZE

Plugs into 1 full length PCI Slot. 13" x 4.1"

Memory Depth:	Board Occupies:
2MB	1 full length slot
8MB & 16MB	2 full length slots
128MB & 512MB	3 <sup>†</sup> full length slots
1GB & 2GB	3 <sup>†</sup> full length slots

<sup>†</sup> Contact factory for optional 2-slot deep memory solution.

## POWER (IN WATTS)

+5 V		
Memory Depth	Worst case	Typical
2M	28.6	26.0
8M	31.6	29.0
16M	31.6	29.0
128M	33.6	30.0
512M	36.1	32.0
1G	36.1	32.0
2G	38.6	34.0



### INPUT

Input Connector: 68 Pin MDR connector  
 Number of Data Lines: 32, 16, or 8; Software-selectable  
 Input Type: Single Ended or Differential, factory set.  
 Can not be modified in the field.  
 Input Levels:  
 Single Ended: CMOS (0 to 5 Volts),  
 CMOS (0 to 3.3 Volts)  
 Differential: ECL or PECL

### CLOCK

Internal Clock Rate: MHz: 100, 50, 20, 10, 5, 2, 1  
 kHz: 500  
 External Clock: Standard  
 External Clock Type: Single Ended or Differential, set to the  
 same type as data lines  
 External Clock Level: Set to the same type as data lines.  
 CMOS/TTL inputs are 3.3 Volt tolerant.  
 Single-Ended: CMOS (0 to 5 Volts),  
 CMOS (0 to 3.3 Volts),  
 TTL (0 to 5 Volts);  
 Software-selectable  
 Differential: ECL, PECL; Software-selectable  
 Max. External Clock Frequency: 100 MHz  
 Min. External Clock Frequency: DC  
 Impedance: 50 Ω

### TRIGGERING

Source: External Trigger or Software  
 External Trigger: Standard  
 Trigger Type: Single Ended or Differential, set to the  
 same type as data lines  
 Trigger Level: Set to the same type as data lines.  
 CMOS/TTL inputs are 3.3 Volt tolerant.  
 Single-Ended: CMOS (0 to 5 Volts),  
 CMOS (0 to 3.3 Volts),  
 TTL (0 to 5 Volts);  
 Software-selectable  
 Differential: ECL, PECL; Software-selectable  
 Slope: Positive or Negative  
 Post-Trigger Depth: 8 bits 256 point minimum  
 128 point resolution  
 16 bits 128 point minimum  
 64 point resolution  
 32 bits 64 point minimum  
 32 point resolution

### MULTI-CARD SYSTEMS

Operating Mode: Master/Slave or Multiple/Independent  
 Maximum Number of Cards:  
 Master/Slave: 2M models: 2 to 8 cards  
 8M & 16M models: 2, 3 or 4 cards  
 128M & higher models: 2 or 3 cards  
 Multiple/Independent: Limited by backplane

### PCI BUS INTERFACE

Plug-&-Play: Fully supported  
 Bus Mastering: Fully supported  
 Bus Width: 32 bit  
 Bus Throughput: 100 MB/s to PC Memory  
 Compatibility: All PCI compliant computers

### OPERATING SYSTEMS SUPPORTED

Windows 98/ME/NT\* CompuScope Driver version 3.60.22  
 \* Version 4, SP3 or higher  
 Windows 2000\*/XP CompuScope Driver version 4.xx.xx  
 \*\* SP1 or higher

### SOFTWARE DEVELOPMENT KITS (SDK)

CompuScope SDK for C/C# for Windows  
 CompuScope SDK for MATLAB for Windows  
 CompuScope SDK for LabVIEW for Windows  
 CompuScope SDK for LabWindows/CVI for Windows

### APPLICATION SOFTWARE

GageBit Application for Windows

### ELECTROMAGNETIC COMPATIBILITY

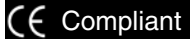
EC Council Directive 89/336/EEC   
 EN 61326 Class A  
 IEC 61000-4-2 Electrostatic Discharge (Performance Criterion B)  
 IEC 61000-4-3 RF Electromagnetic Field (Performance Criterion A)  
 IEC 61000-4-4 Electrical Fast Transient/Burst (Performance Criterion B)  
 IEC 61000-4-5 Power Surge (Performance Criterion B)  
 IEC 61000-4-6 Conducted RF (Performance Criterion A)  
 IEC 61000-4-11 Voltage Dips & Interruptions (Performance Criterion B)  
 EN 61000-3-2 AC Power Line Harmonics Emissions  
 AS/NZS 2064  
 Australian emissions standard for Industrial, Scientific & Medical Equipment  
 Compliance demonstrated on a single card configuration

### MEMORY MODE OPERATION

Data Storage: In on-board memory  
 On-board Memory Size: 2 MB, 8 MB, 16 MB, 128 MB, 512 MB, 1 GB, 2 GB

Width	2 M	8 M	16 M	128 M	512 M	1 GB	2 GB
8 bit	2 million 8-bit words	8 million 8-bit words	16 million 8-bit words	128 million 8-bit words	512 million 8-bit words	1 billion 8-bit words	2 billion 8-bit words
16 bit	1 million 16-bit words	4 million 16-bit words	8 million 16-bit words	64 million 16-bit words	256 million 16-bit words	512 million 16-bit words	1 billion 16-bit words
32 bit	512K 32-bit words	2 million 32-bit words	4 million 32-bit words	32 million 32-bit words	128 million 32-bit words	256 million 32-bit words	512 million 32-bit words



#### MATERIALS SUPPLIED

One CompuScope 3200 card  
One Hardware Manual  
Pleated Foil Cable  
One Gage CompuScope CD  
Includes GageBit Software

#### OPTIONAL ACCESSORIES

CS3200: Buffer Board  
CS32x0: BNC Breakout Board

#### WARRANTY

One year parts and labor

All specifications subject to change without notice;  
specifications are not guaranteed under all possible combinations of modes of operation.

#### ORDERING INFORMATION

##### Hardware & Upgrades

###### CMOS or TTL

CompuScope 3200 - 2M	320-161-001
CompuScope 3200 - 8M	320-161-002
CompuScope 3200 - 16M	320-161-003
CompuScope 3200 - 128M	320-161-004
CompuScope 3200 - 512M	320-161-005
CompuScope 3200 - 1G	320-161-006
CompuScope 3200 - 2G	320-161-007

###### Differential ECL

CompuScope 3200 - 2M	320-161-020
CompuScope 3200 - 8M	320-161-021
CompuScope 3200 - 16M	320-161-022
CompuScope 3200 - 128M	320-161-023
CompuScope 3200 - 512M	320-161-024
CompuScope 3200 - 1G	320-161-025
CompuScope 3200 - 2G	320-161-026

CS3200 Memory Upgrades	Contact Factory
Master Multi-Card Upgrade	320-181-103
Slave Multi-Card Upgrade	320-181-104
CS3200: Buffer Board	320-181-105
CS32x0: BNC Breakout Board	320-181-143

##### Software Development Kits (SDKs)

Gage SDK Pack on CD	200-113-000
CompuScope SDK for C/C#	200-200-101
CompuScope SDK for MATLAB	200-200-102
CompuScope SDK for LabVIEW	200-200-103
CompuScope SDK for LabWindows/CVI	200-300-100

*All Upgrades performed at the factory.*

900 N. State St.  
Lockport, IL 60441-2200

#### Toll-Free (US and Canada):

phone 1-800-567-4243  
fax 1-800-780-8411

#### Direct:

phone +1-514-633-7447  
fax +1-514-633-0770

#### Email:

[prodinfo@gage-applied.com](mailto:prodinfo@gage-applied.com)

To find your local sales representative  
or distributor or to learn more about  
GaGe's products visit:

**[www.gage-applied.com](http://www.gage-applied.com)**

Updated January 10th, 2006

Copyright © 2004, 2006 Gage Applied Technologies. All rights reserved.