

We offer the widest range of high-speed and high-resolution digitizers available on the market today. Our powerful PC-based instrumentation products allow you to create reliable, flexible and high-performance solutions quickly and easily.

Reduce development time and costs for testing complex applications such as radar, wireless communications, spectroscopy, etc. by using our GageScope software or SDKs.

APPLICATIONS

Non-destructive testing
Ultrasonic testing
Imaging
Lidar
Radar
Manufacturing test
ATE
Embedded digitizer

CompuScope 1220

Versatile waveform digitizer card for PCI bus



Ideal digitizer for synthetic instrumentation, manufacturing test, and imaging applications.

FEATURES

- 12 bit, 20 MS/s A/D sampling on two simultaneous channels
- Single-ended inputs
- Up to 1 GigaSample of on-board acquisition memory
- Enhanced external clocking capability for better system synchronization at low sampling rates
- Fast data transfer rate to PC memory
- Programming-free operation with GageScope® software
- Software Development Kits available for LabVIEW, MATLAB, C/C#

CompuScope 1220 Simplified Block Diagram

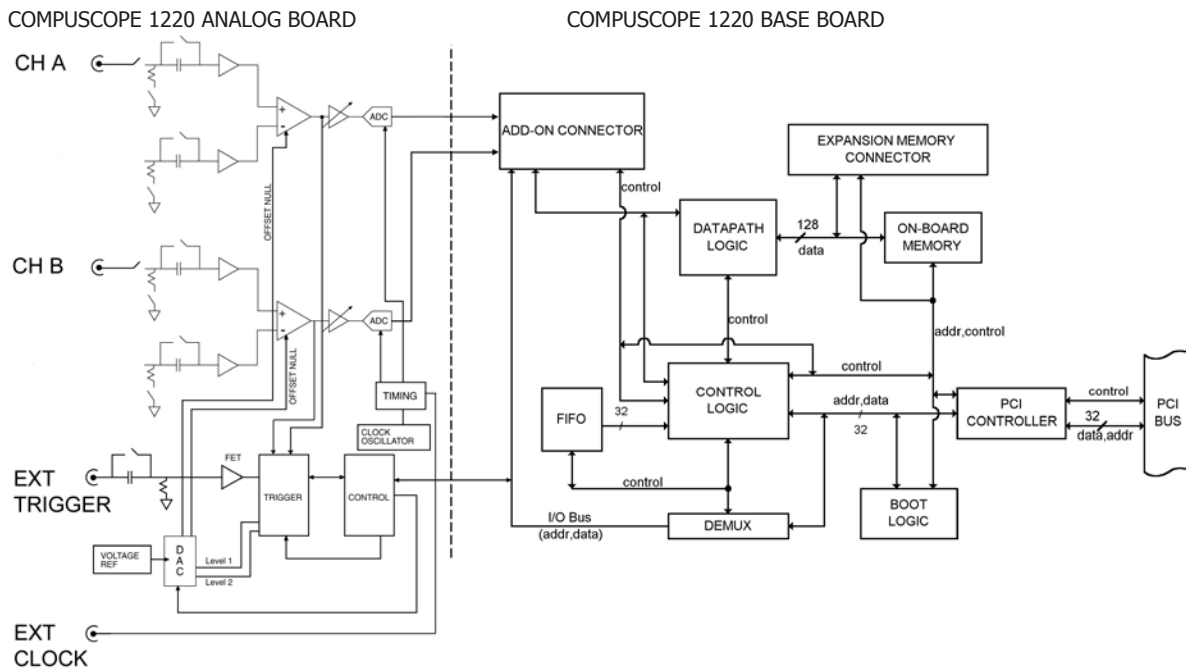

COMPUSCOPE 1220

A CompuScope 1220 card for PCI bus can simultaneously sample two analog signals at speeds up to 20 MS/s with 12 bit resolution and store the data in the on-board memory.

12 BIT 20 MS/s SAMPLING

CompuScope 1220 uses state-of-the-art data conversion technology to provide dual-channel simultaneous sampling rate of 20 MS/s with 12 bit resolution. Each channel has its own ADC chip, eliminating the need for multiplexing the inputs which invariably results in increased noise and lower performance.

EXTERNAL CLOCKING ENHANCEMENTS

The CompuScope 1220 was designed to solve a wide range of applications requiring both the synchronization of the digitizer to the test or data acquisition system as well as the best possible performance at lower sampling rates (below 1 MS/s).

The CompuScope 1220 can thus be externally clocked between 20 MS/s and 1 kS/s.

With full programming control over the signal conditioning front-end, a top performance A/D stage and a standard External Clock feature, the CompuScope 1220 is ready for such critical applications as NDT, imaging, and ATE.

HIGH IMMUNITY TO DIGITAL NOISE

In order to isolate the high-frequency analog circuitry from PCI bus-related digital electronics, a two-board piggyback configuration is used.

This scheme allows maximum separation of analog and digital grounds, thereby providing high immunity to digital noise.

MEMORY DEPTH

CompuScope 1220 is available with memory depths of 1M, 4M, 8M, 64M, 256M, 512M and 1G (12-bit samples mapped into 16-bit words). This memory can be used as a circular buffer for storage of pre- and post-

trigger data.

The memory is divided equally between the two input channels, i.e. a 1 M board provides 512 k of memory per channel.

The data stored in the CompuScope 1220 memory can be transferred to the system RAM for post-processing, display or storage to hard disk over the PCI bus.

FAST BUS THROUGHPUT

The high-speed, 32 bit, bus-mastering interface to the PCI bus allows the data from the on-board memory of the CompuScope 1220 to be transferred to the system RAM, or any other PCI destination, at sustained rates of up to 50 MB/s under single-tasking operating systems. Under Windows, this rate depends on the architecture of the user application. Under controlled conditions, it is still possible to achieve 50 MB/s recording speed to the system RAM.

BUS MASTERING

CompuScope 1220 is fully capable of becoming a PCI bus master in order to transfer data at the maximum rate of 50 MB/s.

A PCI bus Master is a card which can take control of the bus and transfer data to any PCI target device such as system RAM without any involvement from the CPU.

FLEXIBLE TRIGGERING

CompuScope 1220 features flexible, oscilloscope-like analog triggering.

An analog comparator provides triggering from any one of the two input channels, from an external signal or from software.

In addition to the trigger source, trigger level and slope are also selectable by software, making the trigger system similar to traditional oscilloscopes.

MULTI-CHANNEL TRIGGERING

A very unique feature of CompuScope 1220 trigger system is the ability to trigger a multi-card Master/Slave system from any one of the input channels.

For example, in a 16 channel system, consisting of 8 Master/Slave CompuScope 1220 cards, the user can set the trigger conditions to be such that the system trigger from any channel.

Trigger level and slope can be defined independently for each channel.

This capability is very powerful for applications in which the trigger signal can come from any one of the sensors being used. Examples are explosion test, material stress analysis, high energy particle detection etc.

EXTERNAL CLOCK

External clock is a standard feature on the CompuScope 1220. This feature is useful when A/D sampling must be done coherently with the rest of the system.

The External Clock must be a TTL signal with a maximum frequency of 20 MHz and minimum frequency of 1 kHz.

It is very important to maintain the duty cycle of the external clock of $50\% \pm 5\%$. Failure to supply a clock with duty cycle in this range can result in invalid data.

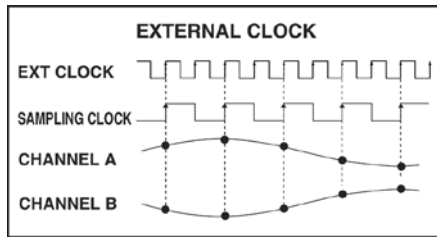

The external clock is provided through a BNC connector.

MULTIPLE RECORD

Even though the PCI bus allows very fast data throughput to system RAM, there may still be applications in which data bursts cannot be off-loaded either because of very fast trigger repeat frequency or because of software limitations.

Multiple Recording allows CompuScope 1220 to capture data on successive triggers and stack it in the on-board memory. Up to 4,194,304 triggers can be captured in multiple record mode.

GageScope Software can display the stacked data as individual acquisitions. Software drivers also provide support for accessing Multiple Record data.

Once the CompuScope 1220 has finished capturing a Multiple Record segment, the trigger circuitry is automatically re-armed within 5 sample clock cycles to start looking for the next trigger. No software intervention is required.

Multiple Recording is useful for applications in which a series of bursts of data have to be captured in quick succession and there is not enough time to off-load the data to the PC memory.

Another situation in which Multiple Recording may be used is when data storage has to be optimized. These are cases in which only certain portions of the incoming signal are of interest and data capture during the dead-time between successive portions is not useful.

Examples of these situations are radar pulses, ultrasound data, lightning pulses, imaging signals and explosion testing.

MULTI-CARD SYSTEMS

One of the unique features of Gage's CompuScope cards is the multi-card system that can be configured.

A multi-card system, comprised of one Master and up to 7 Slave CS1220 boards, can be ordered from the factory if the user wants to capture more than two channels with a common clock and trigger. A board-to-

board interconnect is supplied with the system. This interconnect carries all the signals needed for proper synchronization.

The following Master/Slave systems can be configured.

- For 1M memory models: 2, 4, 6 or 8 cards can be configured
- For 4M and 8M memory models: 2, 3 or 4 cards can be configured
- For 64M and higher memory models: 2 or 3 cards can be configured

GageScope can then display all channels from these boards on the same screen. Software drivers also support such Master/Slave systems.

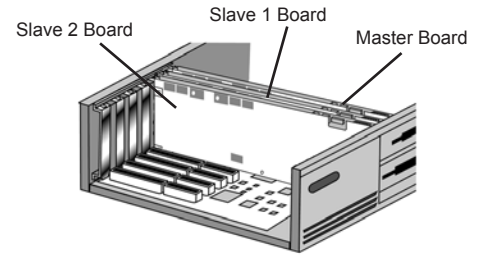

SYSTEM REQUIREMENT

PCI-based computer with at least one free full length PCI slot, 128 MB RAM, 50 MB hard disk and SVGA video.

SIZE

Plugs into one full length PCI Slot, 13" x 4.1".

1M Acquisition Memory	1 slot
4M Acquisition Memory	2 slots
8M Acquisition Memory	2 slots
64M Acquisition Memory	3 [†] slots
256M Acquisition Memory	3 [†] slots
512M Acquisition Memory	3 [†] slots
1G Acquisition Memory	3 [†] slots

[†] Contact factory for optional 2-slot deep memory solution.

POWER (IN WATTS)

+5 Volts		
Acquisition Memory	Worst case	Typical
1M	25.0 W	17.5 W
4M	28.0 W	20.5 W
8M	28.0 W	20.5 W
64M	32.5 W	23.5 W
256M	32.5 W	23.5 W
512M	32.5 W	23.5 W
1G	32.5 W	23.5 W

Note: Power connector on the deep memory board of 64M, 256M, 512M and 1G models must also be connected using a Y-cable.

CHANNELS A & B

Inputs per card:	2 single-ended inputs
Impedance:	1 M Ω , 35 pF or 50 Ω , software selectable
Coupling:	AC or DC
Connector:	1 BNC per channel
Resolution:	12 bits
A/D Type:	Monolithic, 16 bit oversampling with decimation filter, operating in 12-bit mode
Full Voltage Ranges:	± 50 mV, ± 100 mV, ± 200 mV, ± 500 mV, ± 1 V, ± 2 V, ± 5 V, ± 10 V

Analog Bandwidth:

Input Range	-3 dB Point
±10 V	5 MHz
±5 V	5 MHz
±2 V	10 MHz
±1 V	10 MHz
±500 mV	10 MHz
±200 mV	10 MHz
±100 mV	10 MHz
±50 mV	10 MHz

Absolute Max. Amplitude:

1 MΩ impedance: ±15 Volts (continuous)
 50 Ω impedance: ±5 Volts (continuous),
 ±15 Volts (for 1 ms duration)

DC Accuracy:

Input Range	Accuracy
±10 V	±0.5%
±5 V	±0.5%
±2 V	±0.5%
±1 V	±0.5%
±500 mV	±0.5%
±200 mV	±0.5%
±100 mV	±1%
±50 mV	±2%

Sampling Rates:

20 MS/s, 10 MS/s, 5 MS/s, 2 MS/s, 1 MS/s,
 500 kS/s, 200 kS/s, 100 kS/s, 50 kS/s,
 20 kS/s, 10 kS/s, 5 kS/s, 2 kS/s, 1 kS/s

Protection:

1 MΩ Impedance: Diode Clamped
 50 Ω Impedance: No protection

DYNAMIC PARAMETERS

Measured using 5 MHz sine wave input at 20 MS/s with amplitude of 95% of full scale on the ±1 V range. Typical values listed below.

SNR: 55 dB
 SFDR: 57 dB
 ENOB: 8.9 bits

ACQUISITION MEMORY

Data Storage: In on-board memory
 Memory Sizes: 1 Msamples, 4 Msamples, 8 Msamples,
 64 Msamples, 256 Msamples,
 512 Msamples, 1 Gsamples
 Maximum Depth: Up to half on-board memory per channel

TRIGGERING

Number of Trigger Inputs: 2 per card
 Trigger Source: CH A, CH B, Ext or Software
 Input combination: Wired-OR
 Type: Analog triggering
 Sensitivity: ±20% of full scale
 Level Accuracy: ±10% of full scale
 Slope: Positive or Negative, software selectable
 Post Trigger Data: 64 pts minimum in single record acquisition
 128 pts minimum in multiple record acquisition
 Can be defined with a 64 point resolution

EXTERNAL TRIGGER

Impedance: 1 MΩ, 30 pF
 Input Type: Single-ended analog
 Amplitude: Absolute Max ±15V
 Voltage Range: ±1V and ±5V
 Bandwidth: 10 MHz
 Connector: BNC

INTERNAL CLOCK

Source: 20 MHz Clock Oscillator
 Accuracy: ±50 ppm (0 to 70 degrees Celsius)

EXTERNAL CLOCK

Maximum Frequency: 20 MHz
 Minimum Frequency: 1 kHz
 Signal Level: TTL
 Termination Impedance: 50 Ω
 Required Duty Cycle: 50% ±5%, -0% at 20 MHz
 Coupling: DC

MULTIPLE RECORD

Pre-trigger Data: None
 Record Length: 128 points minimum.
 Can be defined with a 64 point resolution
 Maximum # of Triggers: 4,194,304

MULTI-CARD SYSTEMS

Operating modes: Master/Slave or Multiple Independent
 Maximum Number of Cards
 Master/Slave: 2 to 8 cards for 1M memory
 2, 3 or 4 cards for 4M or 8M memory
 2 or 3 cards for 64M, 256M, 512M and 1G
 Multiple/Independent: Limited by the backplane of the PC
 Maximum # of Channels in Master/Slave Mode: 16 at 20 MS/s (for 1M models)

MASTER/SLAVE SYSTEM TRIGGERING

Number of Trigger Inputs: 2 per card
 Trigger Source: CH A, CH B, EXT or Software
 (Master card only)
 Input combination: Wired-OR
 Sensitivity: ± 20% of full scale
 Level Accuracy: ± 10% of full scale
 Slope: Positive or Negative, software selectable

PCI BUS INTERFACE

Plug-&-Play: Fully supported
 Bus Width: 32 bits
 Bus Speed: 33 MHz
 Compatibility: 5 Volt PCI-compliant slot

OPERATING SYSTEMS SUPPORTED

Windows 98/ME/NT* CompuScope Driver version †3.60.22
 * Version 4, SP3 or higher
 Windows 2000**/XP CompuScope Driver version 4.xx.xx
 ** SP1 or higher



APPLICATION SOFTWARE

GageScope: Windows-based software for programming-free operation

LITE Edition:	Included with purchase, provides basic functionality
Standard Edition:	Provides limited functionality of advanced analysis tools, except for Extended Math
Professional Edition:	Provides full functionality of all advanced analysis tools

SOFTWARE DEVELOPMENT KITS (SDK)

CompuScope SDK for C/C# for Windows*
CompuScope SDK for MATLAB for Windows
CompuScope SDK for LabVIEW for Windows

*C/C# SDK is compatible with LabWindows/CVI 7.0+ compiler.
Visual Basic.NET support available with purchase of C/C# SDK.

Contact your Gage Sales Agent for information on Linux support.

ENVIRONMENTAL

Operating Temperature:	5 degree Celsius to 40 degree Celsius
Relative Humidity:	Less than 80%, non-condensing
Maximum Altitude:	2,000 meters

WARRANTY

One year parts and labor
Certificate of NIST Traceable Calibration included.

All specifications subject to change without notice; specifications are not guaranteed under all possible combinations of modes of operation.

ORDERING INFORMATION

Hardware & Upgrades

CompuScope 1220-1M	122-001-002
CompuScope 1220-4M	122-001-003
CompuScope 1220-8M	122-001-004
CompuScope 1220-64M	122-001-005
CompuScope 1220-256M	122-001-006
CompuScope 1220-512M	122-001-007
CompuScope 1220-1G	122-001-008
CS1220 Memory Upgrades	Contact Factory
Master Multi-Card Upgrade	122-181-002
Slave Multi-Card Upgrade	122-181-003

GageScope Software

GageScope: Lite Edition	Included
GageScope: Standard Edition (with Purchase of CompuScope Hardware)	300-100-351
GageScope: Professional Edition (with Purchase of CompuScope Hardware)	300-100-354

Software Development Kits (SDKs)

Gage SDK Pack on CD	200-113-000
CompuScope SDK for C/C#	200-200-101
CompuScope SDK for MATLAB	200-200-102
CompuScope SDK for LabVIEW	200-200-103

All Upgrades performed at the factory

Updated April 3, 2006

Copyright © 2004, 2005, 2006 Gage Applied Technologies. All rights reserved.

900 N. State St.
Lockport, IL 60441-2200

Toll-Free (US and Canada):

phone 1-800-567-4243
fax 1-800-780-8411

Direct:

phone +1-514-633-7447
fax +1-514-633-0770

Email:

prodinfo@gage-applied.com

To find your local sales representative or distributor or to learn more about GaGe's products visit:

www.gage-applied.com