

CompuScope 8500 product introduction

CompuScope 8500 is a single channel, 500 MS/s, 8-bit, waveform digitizer card for the PCI Bus.

Recognizing that until very recently, almost all multi-Megahertz data acquisition was done using Digital Storage Oscilloscopes under GPIB control, GaGe has ported all the features of these DSOs onto the CompuScope card. This means that you do not have to rethink the solution in terms of a completely unknown data acquisition card. You can simply develop the data acquisition system as if an oscilloscope were being used, but instead use a CompuScope card to take advantage of its attractive price and performance.

Of course, CompuScope cards are much more than just another DSO under GPIB control:

- CS8500 features up to 2 billion samples of on-board acquisition memory.
- Multi-card Master/Slave systems provide from 1 to 8 channels of simultaneous A/D conversion, something normal DSOs simply cannot do.
- Data transfer rates from CompuScope memory to PC memory or extended memory run as high as 80 MB/s for the CS8500 as compared to a few hundred KB/s for GPIB.
- CompuScope cards are easier to program, as Software Development Kits are available for C/C#, MATLAB, and LabVIEW. Operation under Visual Basic.NET and LabWindows/CVI is also possible from the C/C# Software Development Kit.
- CompuScope cards are installed inside the PCI bus chassis, so there is no external box such as a DSO.
- CS8500 cards have standard features such as Multiple Record, which help optimize the use of the on-board memory by stacking data from successive bursts.
- You can also write software for a multi-card system in which all the cards are not in a Master/Slave configuration. GaGe drivers support all these multi-card configurations.

Special features of the CompuScope 8500 include:

- **Bus Mastering**
CompuScope 8500 cards are fully capable of becoming a bus master in order to transfer data at the maximum rate of 80 MB/s.
A bus Master is a card that can take control of the bus and transfer data to any PCI target device such as system RAM without any involvement from the CPU.

CompuScope 8500 connectors and headers

CompuScope cards connect to the outside world through connectors, both analog (BNC) and digital (PCI Bus, Master/Slave, etc.). This section describes these connectors for the CS8500 card.

The connectors and headers on the CS8500 card are shown below:

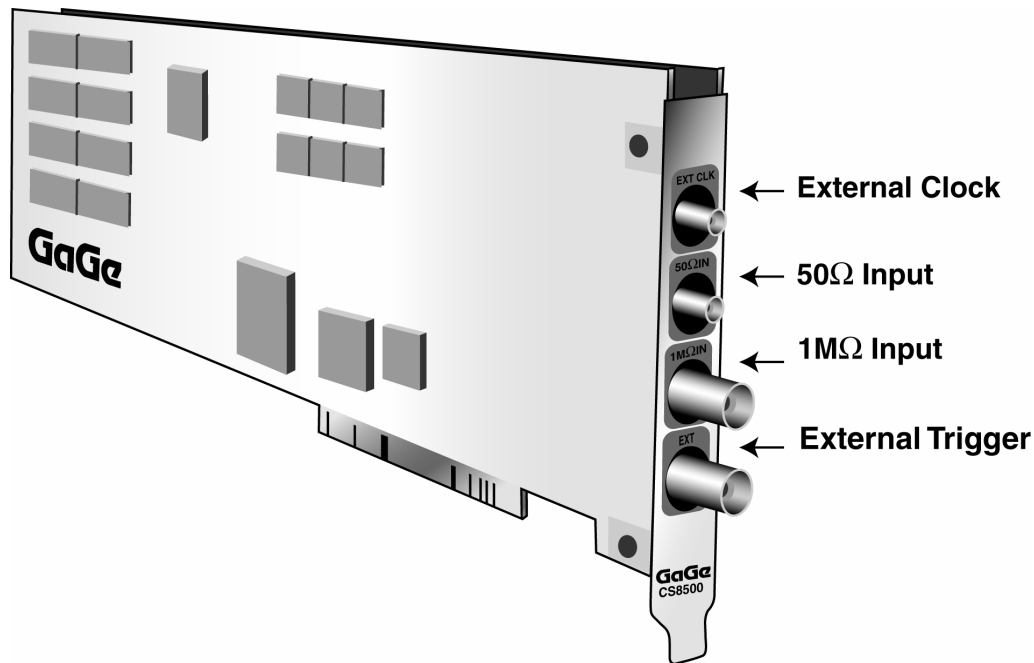

Figure 1: Connectors on CS8500

- **50 Ω input SMA** connector is the single-ended high bandwidth input with a 50 Ω terminating impedance.
- **1 M Ω input BNC** connector is the single-ended reduced bandwidth input with a 1 M Ω impedance
- **External Trigger BNC** connector is used to input an analog or digital signal, which may be used as an External Trigger. External Trigger is defined exactly as in an oscilloscope: this signal can be used to trigger the system but cannot be viewed or digitized.
- **External Clock SMA** connector is used for the External Clock Input, as described in the section labeled *External Clock*.
- **PCI bus connector** is located at the bottom of the printed circuit board. This is an industry standard connector that complies with all specifications of the PCI bus.

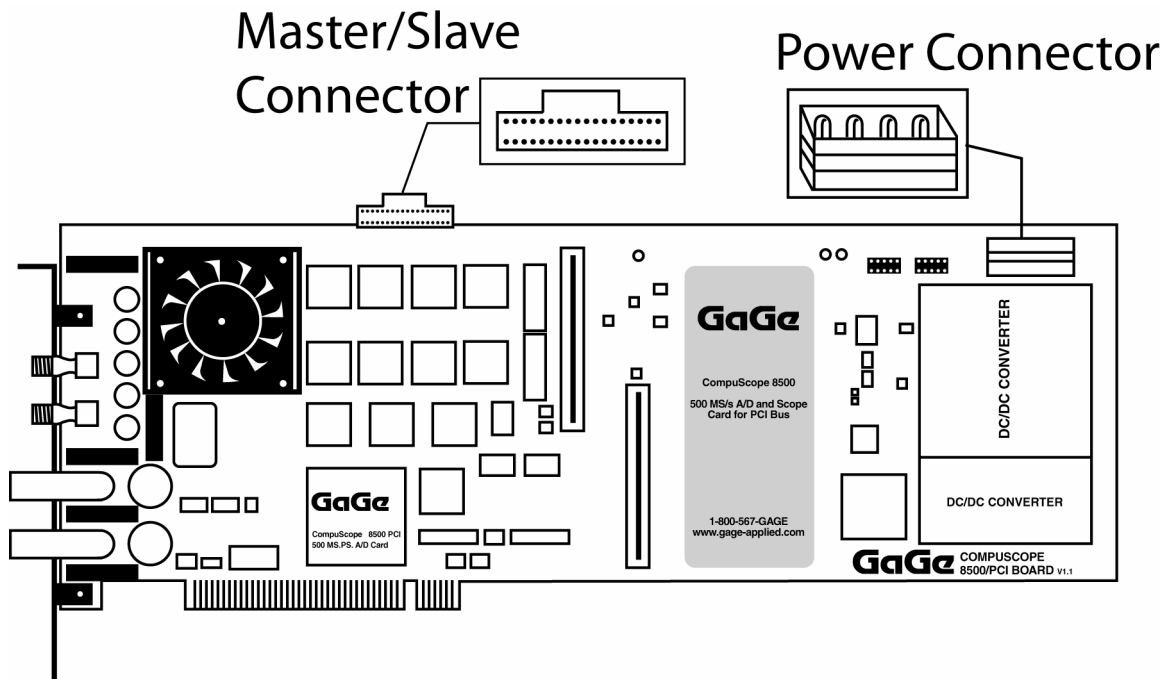

Figure 2: Auxiliary power connector and Master/Slave connector

- **Auxiliary Power Connector.** Power is supplied to the CompuScope 8500 cards via the PCI bus and the Auxiliary Power Connector.

It is absolutely necessary to use the Auxiliary Power Connector when installing one or more CompuScope 8500 cards.

NOTE FOR ALL COMPUSCOPE 8500 USERS:

IF Y-CABLES ARE NOT CONNECTED BETWEEN THE AUXILIARY POWER CONNECTORS OF YOUR COMPUSCOPE 8500 CARDS AND THE POWER SUPPLY OF THE CHASSIS, THE FRONT-END ELECTRONICS OF YOUR COMPUSCOPE 8500 CARD(S) WILL NOT FUNCTION PROPERLY

- **Master/Slave Timing Module (MSTM) connector.** The MSTM connector is located near the top-left corner of the CompuScope 8500. In case of an Independent card (i.e. a card not upgraded to either a Master or a Slave), this connector may not be present.

The Master/Slave Timing Module is used to pass all the signals necessary to synchronize Slave CompuScope 8500 cards with the Master. The Master/Slave connector on the CS8500 card is shown in *Figure 2*.

NOTE FOR MASTER/SLAVE COMPUSCOPE 8500 USERS:

IF A Y-CABLE IS NOT CONNECTED BETWEEN THE POWER CONNECTOR ON THE MASTER/SLAVE TIMING MODULE AND THE POWER SUPPLY OF THE CHASSIS, THE MASTER/SLAVE TIMING MODULE WILL NOT FUNCTION PROPERLY.

NOTE FOR COMPUSCOPE 8500 DEEP MEMORY BOARD USERS:

IF Y-CABLES ARE NOT CONNECTED BETWEEN THE POWER CONNECTORS OF YOUR COMPUSCOPE DEEP MEMORY CARD(S) AND THE POWER SUPPLY OF THE CHASSIS, THE DEEP MEMORY CARD(S) WILL NOT FUNCTION PROPERLY.

CompuScope 8500 compliance statement

Category	Standards or description
EC Declaration of Conformity – EMC	<p>Meets intent of Directive 89/336/EEC for Electromagnetic Compatibility. Compliance was demonstrated to the following specifications as listed in the Official Journal of the European Communities:</p> <p>EN 61326 EMC requirements for Class A electrical equipment for measurement, control and laboratory use. ^{1,2,3}</p> <p>IEC61000-4-2 Electrostatic Discharge (Performance criterion B)</p> <p>IEC61000-4-3 RF Electromagnetic Field (Performance criterion A)</p> <p>IEC61000-4-4 Electrical Fast Transient/Burst Immunity (Performance criterion B)</p> <p>IEC61000-4-5 Power Line Surge Immunity (Performance criterion B)</p> <p>IEC61000-4-6 Conducted RF Immunity (Performance criterion A)</p> <p>IEC61000-4-11 Voltage Dips and Interruptions Immunity (Performance criterion B)</p> <p>EN 61000-3-2 AC Power Line Harmonic Emissions</p>
Australia / New Zealand Declaration of Conformity - EMC	<p>Complies with EMC provision of Radio communications Act per the following standard(s):</p> <p>AS/NZS 2064.1/2 Industrial, Scientific and Medical Equipment: 1992 ^{1,2,3}</p>

- 1. High-quality shielded cables must be used to ensure compliance to the above listed standards**
- 2. Compliance demonstrated on a single card configuration**
- 3. On the host PC used by the customer, all unused back panel slots must be covered with EMI blocking plates**

CompuScope 8500 throughput & maximum PRF

A number of applications require the CompuScope 8500 to acquire data based on a rapidly occurring trigger signal. These high Pulse Repeat Frequency (PRF) applications include imaging, radar, ultrasound and lightning test.

We have performed extensive repetitive capture benchmarks in Single Record mode. In this mode, the signal is captured into on-board CompuScope memory and the captured data are transferred through the PCI bus using PCI bus mastering to PC RAM.

Please note that much higher PRFs will be achieved using CompuScope Multiple Record mode.

The following test results were obtained using a computer configured as follows:

- Pentium III, 1 GHz processor
- 512 MB RAM
- 20 GB disk drive
- Windows 2000
- NT File System
- 33 MHz, 32 bit PCI bus
- All slots support bus mastering

A C application program optimized for fast repetitive capture in single record mode was used for throughput measurements. The CS8500 was operated using this application for many different capture depths and the results are plotted as points in the graph below. The PCI transfer rate was calculated from the linear portion of the curve at high depths.

PCI data transfer rate: 80 MB/s

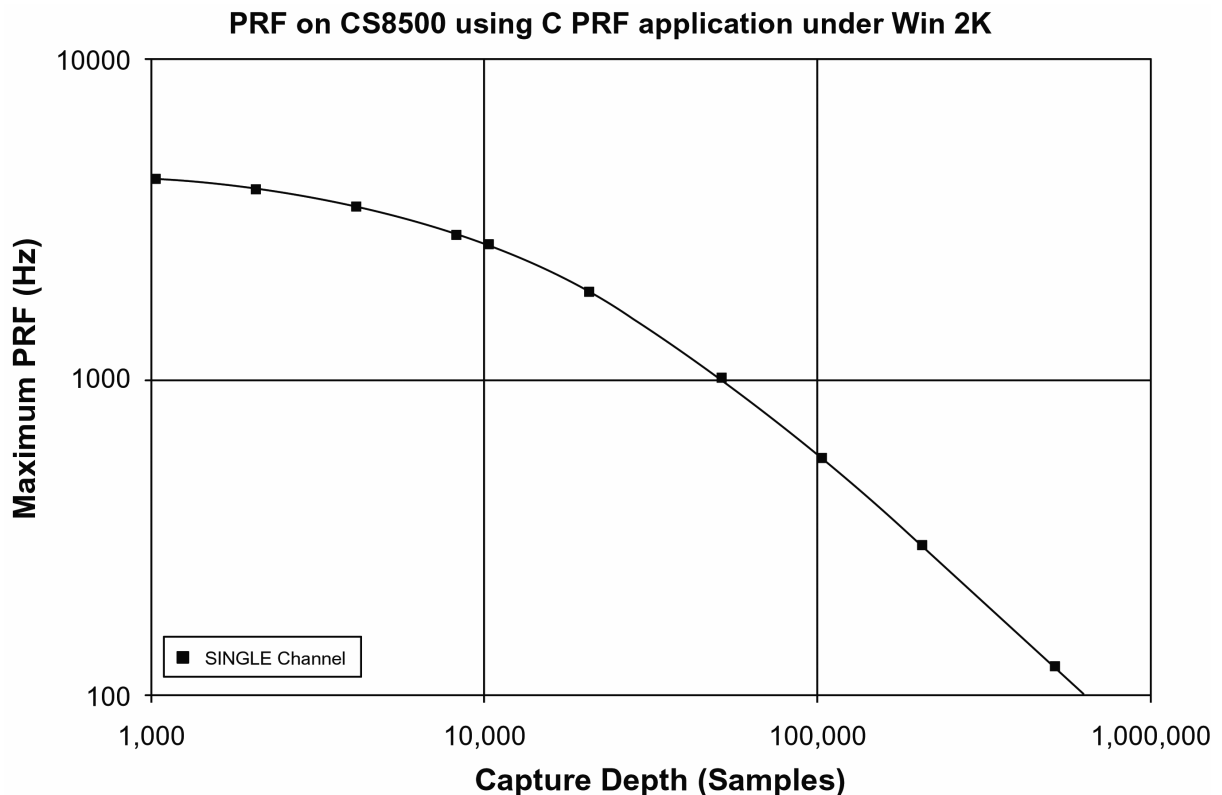

Figure 3: Maximum PRF vs. acquisition length