



* general description

The NET 24A, 48C, 72A, 96C & 120A are Ethernet type digital input / output and counter-timer data acquisition devices. These devices are used to do digital control and pulse counting over an Ethernet based network. The device has built-in TCP/IP networking capabilities and makes use of the EDR Enhanced network protocol to communicate to host devices like PCs and embedded devices.

All Ethernet μ DAQ devices ship with the EDR Enhanced Software Development kit containing the EDR Enhanced Application Program Interface (API). The EDR Enhanced API implements a standard function set ensuring that all functionality stays the same for different bus types. This allows for switching between Ethernet and other bus topologies, like USB, without any software change. It also makes it possible to use Ethernet technology without any knowledge of TCP/IP network programming.



Figure 1 NET 24A

* features

- Ethernet 10/100 Mbps compatible.
- Automatic link speed detection.
- Support remote setup and firmware upgrade.
- No knowledge of network programming is needed
- Support for up to 120 digital I/O lines.
- Support for up to 6 counter-timers
- 16-bit programmable down counters
- Each counter has an external clock line and gate
- Six programmable counter modes
- Automatic programmable I/O port direction.
- Powered by an external power supply
- Dimensions:
 - 24A / 48C / 72A: 45(H) x 80(W) x 148(L) mm
 - 120A / 96C: 60(H) x 80(W) x 148(L) mm

* ordering information

Device	Counters	Digital IO	Bus Type
NET 24A	0	24	ETHERNET 10 / 100 Mbps
NET 48C	6	48	ETHERNET 10 / 100 Mbps
NET 72A	0	72	ETHERNET 10 / 100 Mbps
NET 96C	6	96	ETHERNET 10 / 100 Mbps
NET 120A	0	120	ETHERNET 10 / 100 Mbps

* absolute maximum electrical ratings

Parameter	Symbol	Condition	Rating			Unit
Digital Input Voltage	Vdi	with respect to ground	-0.5 to 5.5			V
Digital Output Voltage	Vdo		-0.5 to 5.5			V
Digital Output Current	Vdoc		±2.0			mA
Storage Temperature	Tst	-	-50 to 150			°C
Operating Temperature	Tot	-	0 to 70			°C
Power Requirements:						
	Pd	Ta = 25°C	Min	Typ	Max	
NET 24A			165	200	250	mA
NET 48C			410	445	495	mA
NET 72A			170	205	305	mA
NET 96C			415	450	595	mA
NET 120A			180	215	415	mA

* digital I/O & counter timer electrical characteristics

Parameter	Symbol	Condition	Min.	Typ.	Max.	Unit
Input High	Vih	Ta = 25°C with respect to ground	2.2		5.5	V
Input Low	Vil		-0.3		0.8	V
Output High	Voh		3.7	5.0		V
Output Low	Vol			0.0	0.4	V
Output Source/Sink Current	Io				2.0	mA
			-1		1	µA
Input Source/Sink Current	Ii					

* digital I/O properties

Parameter	Type
Logic Compatibility	5V & 3.3V TTL Logic Levels
Device Compatibility	Intel 82C55
Maximum read / write speed	< 4ms *
Number of channels:	Channels
NET 24A	24 I/O @ 3 x 8-bit
NET 48C	48 I/O @ 6 x 8-bit
NET 72A	72 I/O @ 9 x 8-bit
NET 96C	96 I/O @ 12 x 8-bit
NET 120A	120 I/O @ 15 x 8-bit

*Dependant on TCP/IP network traffic and routing.

* counter-timer properties

Parameter	Type
Logic Compatibility	5V & 3.3V TTL Logic Levels
Device Compatibility	Intel 82C54
Maximum read / write speed	* < 4ms
Number of channels:	Channels
NET 24A	0
NET 48C	6
NET 72A	0
NET 96C	6
NET 120A	0

* Dependant on TCP/IP network traffic and routing

* software operation characteristics

Parameter	Symbol	Condition	Min.	Typ.	Max.	Unit	
Digital read operation	Dir	No other network traffic @ 100 Mbps		< 4		Millisecond s	
Digital write operation	Dow						
Counter read operation	Cr			< 4		Millisecond s	
Output write operation	Cw			< 4		Millisecond s	
Interrupt latency	Ir				< 4		Millisecond s
					< 10		Millisecond s

* operation

The diagram below shows a typical setup of how to connect to an Ethernet μ DAQ device. The device is connected to an existing Ethernet network. It also needs an external power supply and external equipment via the DB25 connectors. The device runs an onboard operating system and listens to network connections continuously. When the host computer makes a TCP/IP connection, it can execute commands sent via the EDR Enhanced network protocol. This protocol allows for digital I/O and counter-timer commands. It also has a facility to notify the host computer of interrupts. The EDR Enhanced network protocol can also update the unit's firmware remotely, change the network setup and query device properties.

The device can be used to switch relays, mechanical or solid-state. The output is a normal TTL signal therefore the line needs to be buffered to be able to drive the relay. Each application will differ but for a common solution the PC38V will serve as an I/O buffer module. For a more standard installation make use of the PC38G, a mechanical relay module, or the PC37D, a solid-state relay module.

The Ethernet μ DAQ can also be used to monitor digital inputs. A simple interface is a normally open switch with a pull-up resistor. In this case the line will stay high until the switch is closed. For digital inputs the best option would be to optically isolate it. For this purpose the PC43E can be used. This is an eight-channel optical-isolation module.

The counter-timers can be used to count pulses or to generate them. The counters can generally only be used to calculate slower or short burst signals. This is because of the network communications latency, which is not as fast as USB or PCI. This read time will increase as network traffic increases.

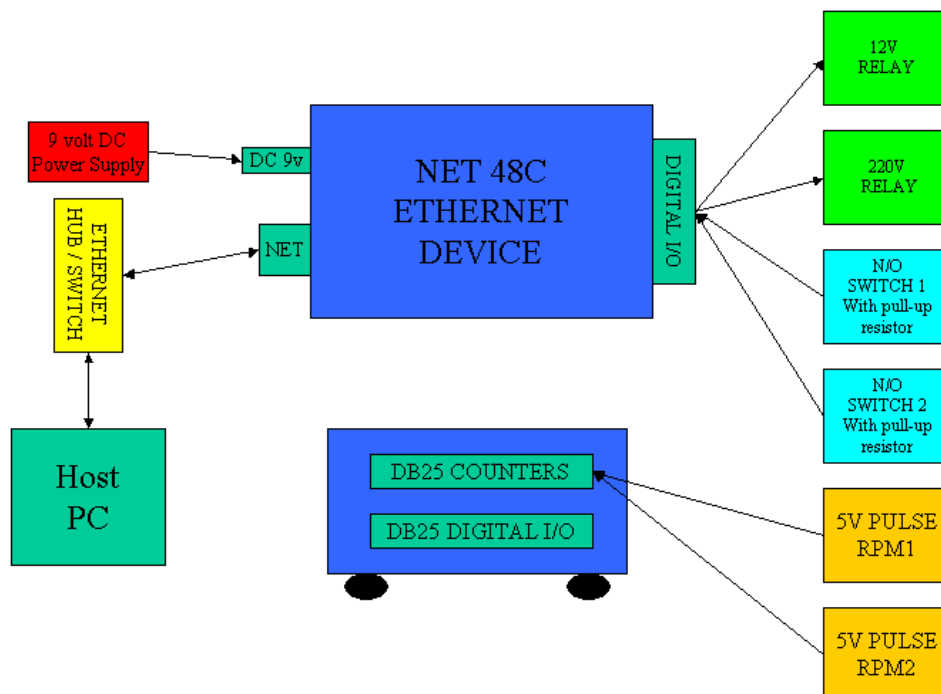

Illustration 1: Typical Setup

* optional accessories

The Ethernet μ DAQs can be used with a wide range of accessories. The table below shows a list of accessories that are compatible with the digital I/O and counter timer Ethernet series of devices.

ADPT-25-S	Short MicroDAQ mini Screw Terminal Adaptor
ADPT-25-M	Medium MicroDAQ mini Screw Terminal Adaptor
DB25M/F	DB25 (M) to DB25 (F) Multi-core Screened Cable
ADPT-2526	DB25 (F) & IDC26 (M) to 27way Screw Terminal Adaptor
PC-52A2	Multi I/O Adaptor (2x) 8ch; (4x) 4ch Analog I/P; (1x) 4ch Analog O/P
PC-43A2	Multi I/O Adaptor (1x) 16ch; (3x) 8ch Digital I/O
PC-37D	8 Channel Opto-22 Solid State Relay Module
PC-37E	16 Channel Opto-22 Solid State Relay Module
PC-37F	24 Channel Opto-22 Solid State Relay Module
PC-38X	24 Channel I/O Driver Module
PC-43E	8Channel Digital Opto-Isolator I/P Module
PC-43B	16 Channel Digital Opto-Isolator I/P Module
PC-43C	24 Channel Digital Opto-Isolator I/P Module

* software support

All μ DAQ products are supported by the EDR Enhanced Software Development Kit and have operating system drivers for Windows and Linux. The EDR Enhanced SDK provides many examples for all popular programming environments.

The EDR Enhanced API implements the network protocol therefore no knowledge of network programming is needed. The digital I/O and counter-timers functions are transparent across the network. This property makes it easy to switch from USB or PCI to Ethernet without recompiling or changing the software.

Development support

- C++, Windows and Linux
- Borland Delphi
- Borland C++ builder
- Visual Studio .NET
- Java
- KDevelop & QT
- Labview



* contact details

Eagle Technology

Postal Details:
31-35 Hout Street
Cape Town
South Africa

Phone: +27 21 423 4943
Fax +27 21 424 4637

Email: eagle@eagle.co.za
<http://www.eagledaq.com>

* document history

The table below lists the document history. A minor revision change will indicate document errors that are edited. A major revision change will indicate an update or change to the document contents or structure.

Revision	Date	Comments
1.3	31/08/2006	Make minor text changes
1.2	13/08/2006	Reformat and update document.
1.1	02/12/2005	- Change read / write / interrupt latency times - Complete power requirements table
1.0	29/11/2005	Original Release.

* copyright and trademarks

Trademarks and Logos in this manual are the property of their respective owners.

* disclaimer

This document is part of the Eagle Technology Literature. This document can be updated, enhanced, changed or removed without prior notice. This document is the property of Eagle Technology, South Africa and hold no currency value, thus cannot be sold or charged for. Notify the writer, Eagle Technology, of any such experience.

© 2005-2007, Eagle Technology, South Africa