

PC 63C

Reed Relay Output Card

User's Manual

**For the IBM PC, PC/XT, PC/AT, PS/2
386, 486, ISA and EISA computers**

All rights reserved. No part of this Publication may be copied, stored in a retrieval system, or transmitted, in any form by any means, electronic, mechanical, by photocopying, recording, or otherwise, in whole or in part, without prior written permission from the Publishers.

First Edition

May 1995

May 1995 Printing

Information furnished in this manual is believed to be accurate and reliable; however no responsibility is assumed for its use, nor for any infringements of patents or other rights of third parties which may result from its use.

IBM, IBM PC/XT/AT and IBM PS/2 are trademarks of International Business Machine Corporation. MicroSoft and MSDOS are trademarks of MicroSoft Corporation.

© Copyright: Eagle Technology

Table of Contents

	Page
Introduction	4
Chapter 1: Installation	4
1.1) Setting the Base Address	5
1.2) Wait State Generation on the PC 63C	8
1.3) Interrupt Jumper Settings	8
1.4) Installation	8
Chapter 2: Interconnections	10
2.1) Connections to Backplane of PC	10
2.2) User Connector	11
2.3) Relay contact points	12
2.4) Power supply connections	12
2.5) External Trigger Line	12
Chapter 3: Register Structure	13
3.1) REEDPA (Reed Port A) Register	14
3.2) READPB (Reed Port B) Register	14
3.3) INTEN (Interrupt Enable) Register	15
3.4) IRES (External Interrupt Reset) Register	15
Chapter 4: Programming Guide	16
4.1) Initialization	16
4.2) Switching Reed Relay	17
4.3) External Triggering	17
4.4) Interrupt Handling	18
Chapter 5: Driver Software	19
5.1) Board Handles	19
5.2) Interrupt Functions	19
Chapter 6: Testing the PC 63C	24
Chapter 7: Troubleshooting the PC 63C	25
Chapter 8: Repair Service	26
Chapter 9: Specifications	27
Appendix A: Base Address Settings	28
Appendix B: Layout Diagram	33

Introduction

The PC 63C reed relay output card is an industrial interface card used to control various devices from the IBM PC/XT/AT. 16 reed relays allows the control of 16 different contact points. Switching of these relays are done by writing to I/O port address within the IBM PC/XT/AT I/O space.

The PC 63C fits into one of the IBM 8 bit expansion slots.

Typical applications

- * PC controlled switching of instrumentation
- * Laboratory Automation
- * Energy management
- * Product testing
- * Energy management

Features

- * On-board wait state generation allows operation on high speed computers
- * Switches up to 16 Reed Relays with full readback capability
- * Signal conditioned (isolated) external trigger line available
- * Interrupt support to allow feedback capability
- * Switching external devices up 10W max.
- * Driver software in C, Pascal, Qbasic Basic and Visual Basic is provided for easy programming. Windows drivers (DLL) including LabView is also available.

PC 63 Package

The PC 63C package consists of:

- PC 63C Interface Card
- PC 63C User's Manual
- EDR Developers Toolkit User Manual + 5¼ or 3½ diskette
- A D37 type male connector
- One 5¼ OR 3½ diskette containing the PC 63C drivers and demonstration software

If any of the items is missing, contact your dealer immediately specifying which components are missing.

Chapter 1: Installation

There are two aspects of the PC 63C that must be configured:

1a) The Base Address

This address determines where the board is accessed. This can be set by a 8-way DIP switch found on the PC 63C Board. The address range are from 0 to 7ffh.

1b) Wait State generation

Some computers have very high I/O bus cycles. In this case it is necessary to slow down these cycles when the computer accesses the PC 63C Board. Additional wait states can be set by means of a jumper on the PC 63C Board.

1.1) Setting the base address

The PC 63C occupies a block of 4 consecutive I/O addresses. The base address setting controls where the block starts. This base address must be unique to the PC 63C only and no other card must occupy this address. If multiple PC 63C boards are installed in one computer then each board must have a different base address.

The base address can be assigned to any location from 0 to 7ffh in 8 byte boundaries. Table 1 shows the I/O addresses occupied by standard interface cards. Refer to the Base Address Setting Table in Appendix A for a list of the various base address settings that the PC 63C can occupy.

The base address setting can be set by adjusting the 8-way dip switch on the PC 63C. Each line on the DIP switch switch compares an address line in I/O space. Switch number 1 compares address line A10; switch number 2: address A9 while switch number 8 compares address line A3. Factory default setting is 280h.

If one of the switches are OFF, then it contributes to the base address. An example is as follows:

$$\begin{aligned} \text{Base Address} &= \text{Switch 2 (Address A9)} + \text{Switch 4 (address A7)} \\ &= 200 + 80 \\ &= 280\text{h} \end{aligned}$$

Table 1: Addresses for standard I/O devices

Address	Standard device
000-1FF	Internal system board
200-20F	Games port
210-217	Expansion unit
220-24F	Reserved
250-257	Not assigned
258-25F	Intel 'Above Board'
260-277	Not assigned
278-26F	Reserved
280-2EF	Not assigned
2F0-2F7	LPT2
2F8-2FF	COM2
300-31F	Prototype Board
320-32F	Hard Disk
330-377	Not assigned
378-37F	LPT1
380-38F	SDLC communications
390-39F	Not assigned
3A0-3AF	Binary comms
3B0-3BF	Mono Display Adaptor
3C0-3CF	Reserved
3D0-3DF	CGA
3E0-3E7	Reserved
3E3-3EF	Not assigned
3F0-3F7	Floppy disk
3F8-3FF	COM1
400-FFF	Not used see below

Table 1: Standard I/O Addresses

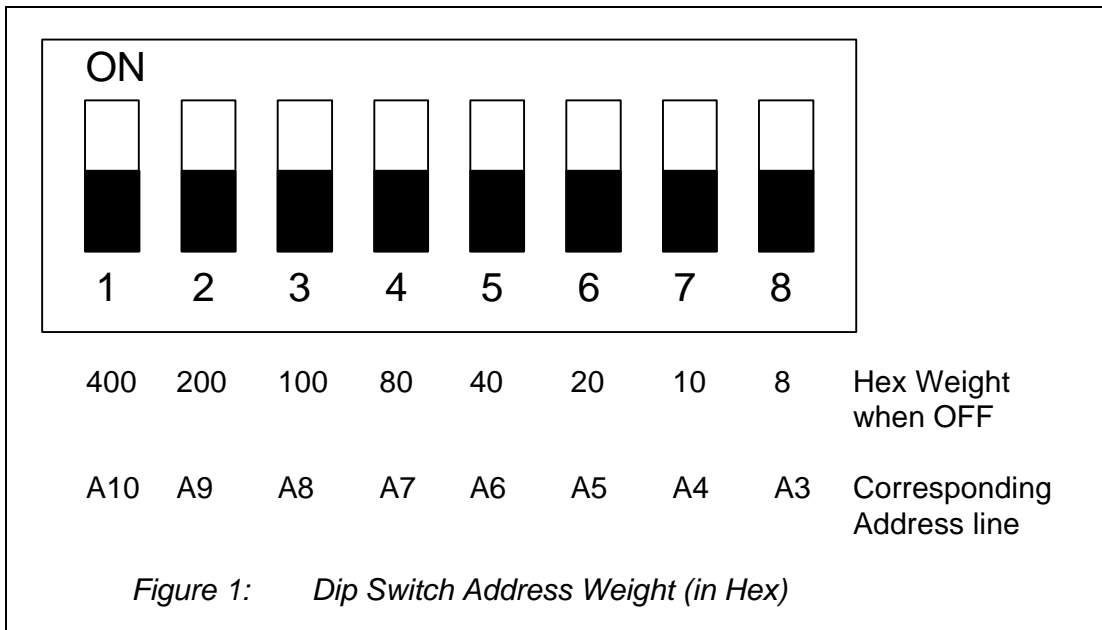

Note that addresses from 400h-7FFh cannot normally be used because these addresses are not normally decoded by some cards and I/O devices in the 0h to 3FFh range.

The PC 63C reed relay board however (and most other members of the PC-XX family) can use these address, if and only if the board at address 400h less than the address of the PC 63C also decodes the extra address.

For example, a PC 63C can be installed at address 300h and another one at address 700h (400h locations apart). However, it would not be advisable to install a PC 63C at address 7F8h. This is because communications port COM1 is installed at 3F8h and does not normally decode these extra addresses.

If your computer has boards not listed in Table 1 (such as LAN adaptors, back-up boards or other engineering boards), you should consult the User's Manuals for these boards for information on the address ranges used.

In most cases, base address of 280h or 300h is a good choice. Address 280h is also the factory default base address setting.

1.2) Wait State Generation on the PC 63C

Additional wait states can be inserted in the I/O bus cycle by changing the jumper setting on JP1 on the PC 63C. This jumper is marked 'Wait State Jumper' on the PC 63C board. Refer to figure 2 for the wait state jumper settings. Note that the factory default setting is zero wait states.

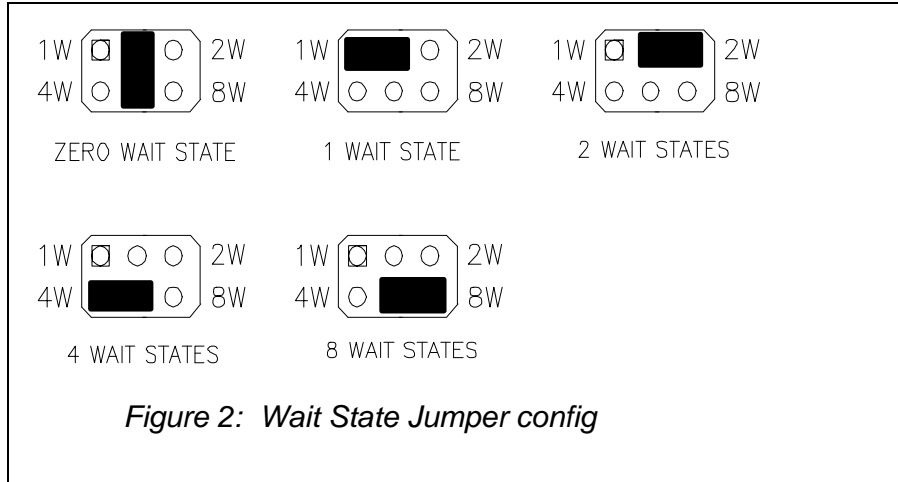

In most cases, only a very small number of computers require additional wait states. If the PC 63C seems to be giving incorrect results then try increasing the wait states until correct results are obtained. If the board still does not produce correct results even after the maximum number of wait states has been inserted then the PC 63C or the host computer are defective and should be serviced.

1.3) Interrupt Jumper Settings

If the external trigger option is used, then it is necessary to configure the interrupt jumper settings. Refer to figure 3 for the interrupt jumper settings.

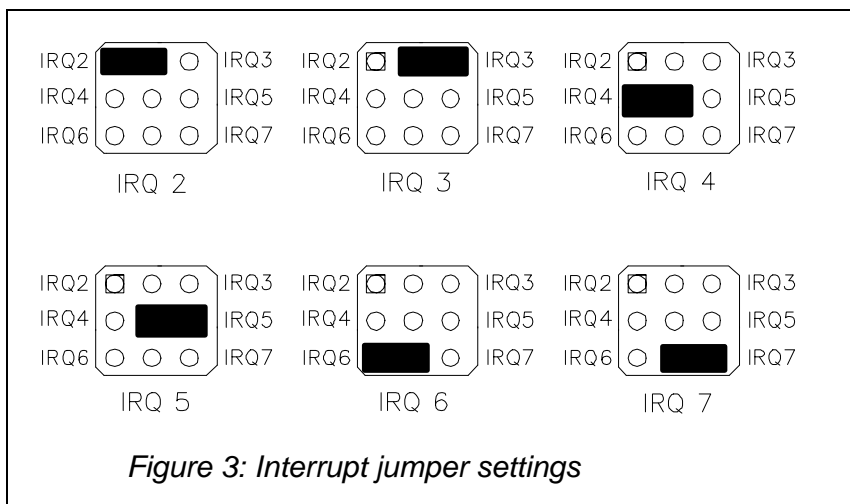

In a standard PC, the interrupt levels are allocated as follows:

Level Level	Allocation
IRQ0	System timer
IRQ1	Keyboard
IRQ2/IRQ9	Display Adaptor
IRQ3	COM1 (if installed)
IRQ4	COM2 (if installed)
IRQ5	LPT2 (if installed)
IRQ6	Floppy disk controller
IRQ7	LPT1 (if installed)

Table 2: Standard interrupt settings

On PC ATs, IRQ2 is used by the system board itself and any interrupt requests on IRQ2 is transparently rerouted to IRQ9.

The default IRQ setting on the PC 63C is IRQ7. Note that unless the interrupt line is specifically enabled by software, the interrupt output from the PC 63C is tri-stated (ie: not connected). It is also tri-stated upon power-up.

1.4) Installation

Requirements:

- * XT/286/386/486 Computer
- * Phillips Screw Driver (or one to match screw on the computer cabinet and bracket)
- * 8 bit or 16 bit bus slot

Procedure:

- a) Switch off the computer and all attached devices
- b) Unplug power cord from the computer and all attached devices.

Warning

Failure to disconnect all power cables can result in hazardous conditions, as there may be dangerous voltage levels present in externally connected cables.

- c) Remove the top cover from the PC. If you are not sure how to do this, consult the manual supplied with the system unit.
- d) Choose any 8 or 16 bit expansion slot and remove the screw from the metal bracket fixed corresponding to the chosen slot.

- e) Align the gold plated edge connector with the edge socket and the rear adaptor slot with the board bracket. Firmly press the board down into the socket on the computer's system board. Ensure that the board's edge connector is in the socket and has not slipped sideways past the socket.
- f) Replace the screw on the bracket and tighten the screw to the back panel.
- g) Replace the computer's cover. Plug in all cables and switch the computer power on. The PC 63C is now installed.

CHAPTER 2: Interconnections

The PC 63C reed relay board plugs into any ISA expansion slot at the gold finger edge connectors J1/J2. The board communicates to the user circuit via a connector mounted on the bracket. This chapter describes these connectors

2.1) Connections to the IBM Bus

The PC 63C board may be plugged into any slot of the computer backplane with the exception of J8 slot of the IBM XTs. All data transfers to and from the host computer is channelled via this connector.

2.2) User Connector

The PC 63C interfaces to the external world via a 37 way D-type female connector. This connector accomodates the following signals:

- * 36 relay contact points
- * +5V, +12V with limited current output and digital ground
- * Optically isolated external trigger point

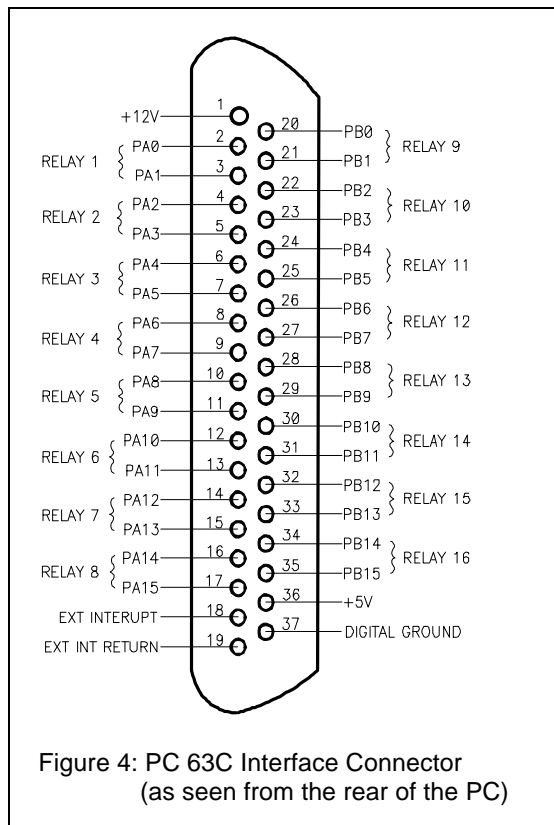

Figure 4 graphically shows the connector together with their pin assignments. Note that the pin connections refer to the pin numbers of the connector when looking into the connector from the rear of the computer. Also note that the pin numbers are embossed on the connector itself.

2.3) The relay contact points

Pins 1 and 7 of each relay connect to the DB 37-pin connector. PA0 and PA1 are contacts of the 1st relay; PA2 and PA3 are contacts of the 2nd relay, etc. Relays 1 thru 8 are controlled by Port 1 (A) and relays 9 thru 16 are controlled by Port 2 (B). Specs on the actual pins connections of the reed relay are shown in appendix B.

There are also LEDs on board the PC 63C that describes the status of the relays. When lit, the relays are enabled or closed. Table 3.2 shows the relationship between data bits, reed relays and the LEDs.

Port No	Bit No	LED	Reed Relay	Port No	Bit No	LED	Reed Relay
Port A	PA0	D1	RL1	Port B	PB0	D8	RL8
Port A	PA1	D2	RL2	Port B	PB1	D9	RL9
Port A	PA2	D3	RL3	Port B	PB2	D10	RL10
Port A	PA3	D3	RL3	Port B	PB3	D11	RL11
Port A	PA4	D4	RL4	Port B	PB4	D12	RL12
Port A	PA5	D5	RL5	Port B	PB5	D13	RL13
Port A	PA6	D6	RL6	Port B	PB6	D14	RL14
Port A	PA7	D7	RL7	Port B	PB7	D15	RL15

Table 5: Data bits, Relays, status LEDs

2.4) Power supply connections

The +5V and +12V power with digital ground are available on the output connector in order to drive external circuitry. However, maximum permissible current drive for both supplies is 500mA. Note that this line is short circuit protected with a 500mA pico fuse (F1 for +5V and F2 for +12V). In the event of a short circuit, these fuses can be replaced. Replacement of the fuses should only be made by a qualified technician. Refer to Figure 3.1 for actual locations of the supply pins.

2.5) External Trigger Line

This line can be used as a trigger line to enable automatic shutdown/switch-on of the relays. This line is optically isolated from the digital circuitry of the PC 63C. The output is connected to the interrupt line of the IBM bus via associated circuitry.

The following voltages are required to generate a pulse on the interrupt line:

0 to 3V logical LOW (0V)
3.1V to 24V logical HIGH (+5V)

The interrupt request line on the IBM Bus requires a positive edge. Hence, you are required to pull the voltage from 0 to (5 thru 24V) in order to enable an interrupt request to be seen by the computer. Note that this line is also connected to one of the bits in a readback register. Hence the status of this line can also be monitored. Refer to chapter 5 for full details on the use of these lines.

CHAPTER 3: Register Structure

At the lowest level, the PC 63C can be programmed using I/O input and output instructions. This chapter contains the information on all the PC 63C registers. Although programming the board is not difficult, it is time consuming and requires detailed knowledge of the PC 63C as well as the operation of the host PC and its operating system. In order to simplify the process, a set of driver libraries is provided. The use of these libraries allow access to all the board's functions and is described in Chapter 5: Programming guide.

The PC 63C occupies 4 consecutive addresses in the computer's I/O space. The layout of these registers are shown in Table 4: PC 63C register structure. The offset of the registers are given as offset addresses from the base address of the board. This base address is set with the Dip Switch as detailed in Chapter 2: Installation.

Offset	Read	Write
0	Port A (REEDPA)	Port A (REEDPA)
1	Port B (REEDPB)	Port B (REEDPB)
2	INTEN Reg	Status Reg
3	IRES Reg	N/A

Table 4: PC 63C register structure

3.1) REEDPA - Port A (offset 0, read/write)

This register controls the first eight reed relays. Bit 0 (LSB) controls the first relay while Bit 7 (MSB) controls the eighth relay. Writing a 0 to any one of the bits in the register disables (opens) the reed relay while writing a 1 to any of the bits energises (closes) the appropriate relay.

REEDPA Register (Offset 0)

Bit 7	Bit 6	Bit 5	Bit 4	Bit 3	Bit 2	Bit 1	Bit 0
PA7	PA6	PA5	PA4	PA3	PA2	PA1	PA0

Reading this register determines the status of each relay.

3.2) REEDPB - Port B (offset 1, read/write)

This register controls the second eight reed relays. Bit 0 (LSB) controls the ninth relay while Bit 7 (MSB) controls the sixteenth relay. Writing a 0 to any one of the bits in the register disables (opens) the reed relay while writing a 1 to any of the bits energises (closes) the appropriate relay.

REEDPB Register (Offset 1)

Bit 7	Bit 6	Bit 5	Bit 4	Bit 3	Bit 2	Bit 1	Bit 0
PB7	PB6	PB5	PB4	PB3	PB2	PB1	PB0

Reading this register determines the status of the last eight relays.

3.3) INTEN - Interrupt Enable register (offset 2: read/write)

This register enables the interrupt line and provides a diags routine for autodetection.

INTEN Register (write mode)

Bit 7	Bit 6	Bit 5	Bit 4	Bit 3	Bit 2	Bit 1	Bit 0
0	0	0	0	0	0	0	IRQEN

INTEN Register (read mode)

Bit 7	Bit 6	Bit 5	Bit 4	Bit 3	Bit 2	Bit 1	Bit 0
x	x	SETFF	TRIG	x	x	x	IRQEN

Bit 0 (LSB): Controls the interrupt line. Setting this bit to 1 enables the interrupt line while setting the bit to 0 disables the line. Note that bit 0 is set to 0 upon power up. Reading back this bit provides the status of the interrupt enable line.

Bits 1 thru 3 Reserved for manufacturing tests. Write 0 to these bits in order to maintain future compatibility. Reading these bits are undefined.

Bit 4: This bit reflects the status of the external trigger line. If this bit is set to a 0 then it means that the user input on the opto-isolator side is set low (between 0 to 3V). If the bit is set to 1 then the input to the opto-isolator is between 3.1 to 24V. Writing to this bit is undefined.

Bit 5: This bit reflects the status of the output of the flip flop that enables the interrupt line. If it is 0 then it means that the interrupt sequence did not take place. If it is a 1 then an interrupt sequence is taking place. Note that the interrupt enable line must be set for interrupt pulses to reach the PC AT BUS IRQ lines. Writing to this bit is undefined.

Bits 6 & 7: Reserved for manufacturing tests. Write a 0 to these bits. Reading these bits are undefined.

3.4) IRES - External Interrupt Reset Register (Offset 3, write only)

This register is used to clear the latched external interrupt.

External Interrupt Register

Bit 7	Bit 6	Bit 5	Bit 4	Bit 3	Bit 2	Bit 1	Bit 0
x	x	x	x	x	x	x	1

Bit 0: Writing a 0 to this bit clears the external interrupt latch thus resetting the external interrupt line. Writing a 1 to this bit is undefined.

Bits 1-7: These bits have no effect on the function of the register. Zeros should be written to these bits for future compatibility.

Chapter 4: Programming Guide

This chapter describes programming the PC 63C at its lowest level. In order to accomplish this, detailed knowledge of chapter 4 and the system hardware is required.

As an alternative to low level programming, driver software is provided with the PC 63C. This is described in Chapter 5.

The advantages of using the driver software are:

- a) Detailed knowledge of the PC 63C is not required.
- b) The Driver Libraries supports multiple boards. In other words, you can cascade boards in the same computer.
- c) The Driver Library is callable from most high level languages.

Programmers who need to incorporate special routines into their application will need to read this chapter. Examples are application programs written in Clarion, Clipper, etc.

Once the PC 63C has been installed into the computer and external connections are made, the board is in an operational state. The PC 63C occupies 4 consecutive I/O addresses starting from the board's base address. The base address is set by the DIP Switch on the PC 63C. Programming the PC 63C is done by using the input/output instructions. Reading and writing to these addresses allows data to be moved to and from the PC 63C.

Reading and writing to these ports typically takes on the form of one of the following instructions:

Language	Port Read	Port Write
'C'	value = inp(addr);	outp(addr, value);
Pascal	value := port[addr];	port[addr] := value;
Assembly	mov al, value mov dx, addr in al, dx	mov al, value mov dx, addr out dx, al

where: addr is the I/O location of the PC 63C registers
 value is the byte read or written to the register

4.1) Initialization

It is preferred to initialize the PC 63C to a known state before performing certain tasks. Note that it is not necessary to perform the procedure because all registers are set to a known state upon power-up.

Procedure:

- a) Reset REEDA (offset + 0) by writing a 0. Verify by reading REEDA register.
- b) Reset REEDB (offset + 1) by writing a 0. Verify by reading REEDB register.
- c) Write 0 to INTEN register (offset + 2).
- d) Write 0 to IRES register (offset + 3).

4.2) Switching the Reed Relays

It is fairly simple to switch any of the reed relays. This is controlled by the REEDA (offset + 0) and REEDB register (offset + 1). Note that an added feature to the PC 63C is that these registers can be read back as well. This allows the user to determine which reed relay is set at any one time. Hence no software copy of the status of these registers are required.

Procedure to switch reed relay ON (eg 1st relay and 8th relay)

- a) Write 1 to REEDA register (offset + 0)
- b) Write 1 to REEDB register (offset + 1)
- c) Verify by reading back REEDA and REEDB register

4.3) External Triggering

This external trigger function is an additional feature present in the PC 63C only. This feature provides an auto switch off / on feature using interrupts. The input line is optically isolated from the digital circuitry. A voltage of 0 to 3V on this input line will give a logical low (0V) while a voltage of 3.1V - 24V will give a logical high (5V). If a +ve edge (low high) transition has occurred then the interrupt line (if enabled) will be pulled high. An interrupt service interrupt routine will then be service. This can be a simple program to switch the Reed relays ON or OFF. It can also be used for any other purpose as well. A detailed example is explained in the EDR Software Developers Toolkit User Manual.

Procedure

- a) Write a 1 to the INTEN Register (Base + 2) in order to enable interrupts.
- b) Write interrupt service routine (ISR).
- c) Ensure that a Low - High transition occurs on the optically isolated input lines.
- d) If so then ISR will be serviced.
- e) Write a 1 to the IRES register (offset + 3) in order to reset the interrupt flip flop.
- f) Return to c)

Note that the status of the external trigger line can be determined by reading back the INTEN register and checking bit 5. If the bit is Low (0V) then the interrupt line is not active. If it is high (5V) then the interrupt line has been serviced.

4.4) Interrupt Handling

The external trigger line is connected to the interrupt line on the PC's I/O channel. This allow external hardware devices to request attention from the host computer. Note that the external trigger line is signal conditioned (optically isolated) thus a higher voltage can be fed into this line. This output of this isolator is TTL compatible and fed into the PC's interrupt system via associated circuitry.

Operation of the ISR is as follows:

- a) Save old interrupt vector corresponding to the desired interrupt.
- b) Set the interrupt vector in the computer's interrupt vector table corresponding to the desired IRQ to point to the interrupt service routine that will service the interrupt.
- c) Write a 1 to the INTEN register (offset + 2) in order to enable the external interrupt latch on the PC 63C.
- d) The signal from the external device is initially low. When it goes high, it is latched by the PC 63C and activates the corresponding IRQ line on the PC Bus.
- e) This causes the host computer to execute the interrupt service routine for the external interrupt. The ISR must contain two statements to allow further interrupts to be received:
 - i) It must contain an end of interrupt (EOI) command to the interrupt controller on the computer system board.
 - ii) It must write a 1 to the IRES register (offset + 3) in order to clear the external interrupt latch.

Chapter 5: Driver Software

Full driver software is supplied with the PC 63C package. Full details are explained in the EDR Software developers kit User Manual. A summary of what these drivers consist of are explained below.

Both DOS and Windows Languages are supported: They are:

DOS Languages:

Borland C/C++ Version 3.1 or 4.0
Microsoft C/C++ Version 6.0 or 7.0
Borland Pascal / Turbo Pascal Version 6.0 or 7.0
Microsoft QuickBasic Version 4.5
National Instruments LabWindows Version 2.0

Windows Languages:

Borland C/C++ 3.1 or 4.0
Microsoft C/C++ 6.0 or 7.0
Borland Pascal / Turbo Pascal Version 6.0 or 7.0

5.1) Board Handles

All EDR functions used above require a board handle as the first parameter. The board handle defines which board is affected by the function call. Using this method has several advantages, For example, there is no need for a 'select board' function; working with parallel boards is much easier; different applications using the EDR at the same time will not conflict with each other.

Board handle are integers obtained by calling EDR_AllocBoardHandle (see 7.2 of EDR Developers Toolkit). Once allocated a board handle must be initialised to the PC 63C before it can be accessed. this is achieved by calling EDR_InitBoard or EDR_InitBoardType (see 7.5 of EDR manual) with the base address or EDR_loadConfiguration (see section 7.8 of EDR manual).

EDR_InitBoard will attempt to detect the PC63C at the base address specified.

5.2) Interrupt functions

Since the external trigger line on the PC 63C is connected to a hardware interrupt, an ISR can be installed using the EDR driver functions provided.

These functions are only callable from C/C++ or Borland/Turbo Pascal.

5.3) Quick Function Reference

The PC 63C Enhanced Reed Relay Board utilises the following functions calls contained in the EDR driver developers toolkit. They are:

Function Name	Description
EDR_DIOPortOutput	Writes a byte of data to the PC63C I/O port
EDR_DIOPortInput	Reads a byte of data from the PC 63C I/O Port. If the port is an output port then the last value written to the port is returned.
EDR_DIOLineOutput	Changes a single line (bit) on the PC63C I/O port. This in turn switches one the reed relays (ON/OFF) on the PC 63C.
EDR_DIOLineOutput	Obtains the status of a single line in a digital I/O port on the PC 63C. This function determines whether any one of the reed relays is ON/OFF.
EDR_InstallISR	Installs an ISR for the specified hardware interrupt request
EDR_UninstallISR	Removes an interrupt service routine that was installed with EDR_InstallISR
EDR_InstallBoardISR	Installs an ISR for a particular type of interrupt installed on the PC 63C.
EDR_UninstallBoardISR	Removes an interrupt service routine that was installed with EDR_InstallBoardISR
EDR_MaskIRQ	Masks or unmaskes a particular IRQ level
EDR_MaskBoardIRQ	Masks or unmaskes a particular board interrupt
EDR_EnableInterrupt	Enables / disables a specified interrupt on hte PC 63C
EDR_ResetInterrupt	Resets an interrupt latch on the PC 63C and sends an EOI command to one of the PCs interrupt controllers on completion of the interrupt
EDR_AllocBoardHandle	Allocates a new board handle to the PC 63C. If no board handles are available then a 0 is returned. This is particularly useful is multiple PC 63C are present in the same.computer.
EDR_FreeBoardHandle	Releases a board handle allocated to the PC 63C making it available to any other PC card
EDR_InitBoardType	Initialises a board and allocates a board handle to it
EDR_ConfigDialog	Diplays a dialog box that allows the user to manually configure the driver for the Board in the computer
EDR_SaveConfiguration	Function writes configuration information to a file for later loading with EDR_LoadConfiguration
EDR_LoadConfiguration	Loads details of the Cards configuration from the file created by EDR_SaveConfiguration
EDR_RestoreDefaults	Restores factory default configuration for a baord attached to a handle
EDR_IsBaseAddressInUse	Checks if any board initialised with EDR is using the specified I/O address
EDR_DetectBoard	Tries to determine the type of board present at a specified I/O address.
EDR_SetBoardType	Changes the board type attached to a board handle
EDR_SetIRQLevel	Set the IRQ level EDR will use for the interrupt ID specified.

An example of the using external trigger interrupt function is shown below. This program is also found in the EDR Driver Toolkit.

```

/*
 * Simple external interrupt demo.
 *
 * Installs an ISR to count external interrupt inputs from the board.
 *
 * Main functions demonstrated:
 *
 *     EDR_InstallBoardISR
 *     EDR_MaskBoardIRQ
 *     EDR_EnableInterrupt
 *     EDR_UninstallBoardISR
 *     EDR_ResetInterrupt
 *
 * Boards supported: All boards with an external interrupt input.
 *
 * (c)1994 David Tinker
 */

#include "..\edr.h"          /* driver functions */

#include <stdio.h>
#include <stdlib.h>
#include <conio.h>
#include <ctype.h>
#include <string.h>
#include <dos.h>

volatile int bh;           /* our board handle */
volatile unsigned long icount=0; /* interrupts processed */

void printerror(int r); /* displays error msg and exits */
void quit(int c);      /* release our board handle and exit */
void interrupt ISR(); /* our interrupt handler */

void main(int argc,char *argv[])
{
int baseaddr;
int boardtype;
int i,j,k,ch;
char s[80];

printf("EXTINT - External interrupt demo\n\n");
if (argc==2) sscanf(argv[1],"%x",&baseaddr);
else baseaddr=0x300;

/* first get a board handle to use */
bh=EDR_AllocBoardHandle();
if (!bh) { /* this should never happen with DOS */
printf("No free board handles\n");
exit(1);
}

/* ask if user wants auto detection */
printf("Autodetect board type (only works with no cables attached) "
"(Y/N) ?");
do { i=toupper(getch()); } while ((i!='Y') && (i!='N'));
printf(" %c\n",i);
if (i=='Y') { /* look for board at specified base address */
i=EDR_InitBoard(bh,baseaddr);
if (i<0) printerror(i);
}
}

```

```

else { /* ask user for type of installed board */
    printf("Choose board type from the following list:\n");
    for (i=1; i<NUMBOARDTYPES; i++) {
        sprintf(s,"%02d ",i);
        EDR_StrBoardType(i,s+3);
        for (; strlen(s)<14; ) strcat(s," ");
        printf("%s ",s);
    }
    printf("\nType the number of the board installed (enter to exit): ");
    gets(s);
    i=atoi(s);
    if (!i) quit(1);
    i=EDR_InitBoardType(bh,baseaddr,i);
    if (i<0) perror(i);
}

/* let the user chose the base address */
EDR_ConfigDialog(bh,-1,-1,-1,-1,-1,-1,-1);

/* copy the board type into a var */
EDR_GetBase(bh,&baseaddr);
EDR_GetBoardType(bh,&boardtype);

/* make sure this board has an external interrupt input */
if (!EDR_ValidInterruptID(boardtype,EDR_INT_EXTINPUT)) {
    printf("This board does not have an external interrupt input.\n");
    quit(1);
}

/* install our ISR for first external interrupt */
/* the second would be EDR_INT_EXTINPUT+1 and so on */
j=EDR_InstallBoardISR(bh,EDR_INT_EXTINPUT,ISR);
if (j<0) perror(j);
EDR_MaskBoardIRQ(bh,EDR_INT_EXTINPUT,0); /* unmask the IRQ */
EDR_EnableInterrupt(bh,EDR_INT_EXTINPUT,1); /* start generating ints */

/* display count until esc is pressed */
printf("\n");
do {
    printf("%lu interrupts have ocured - press esc to exit%c",icount,13);
    if (kbhit()) ch=getch();
    else ch=0;
} while (ch!=27);
printf("\n\n");

/* undo interrupt stuff (very important!) */
EDR_EnableInterrupt(bh,EDR_INT_EXTINPUT,0); /* stop generating ints */
EDR_MaskBoardIRQ(bh,EDR_INT_EXTINPUT,1); /* mask the IRQ */
EDR_UninstallBoardISR(bh,EDR_INT_EXTINPUT); /* remove our ISR */

/* release the board handle (not necessary for DOS) */
EDR_FreeBoardHandle(bh);
}

void interrupt ISR()
/* this gets called for every external interrupt */
{
    icount++;
    EDR_ResetInterrupt(bh,EDR_INT_EXTINPUT); /* signal interrupt complete */
}

```

```
void printerror(int r)
/* displays error msg and exits */
{
char s[80];
EDR_StrError(r,s);      /* convert error number into a string */
printf("%s\n",s);
quit(1);
}

void quit(int c)
/* release our board handle and exit */
{
EDR_FreeBoardHandle(bh);
exit(c);
}
```

Chapter 6: Testing the PC 63C

Before attempting to interface the PC 63C with your application, it is essential that you test the board first. This is done using the following Procedure:

Install the PC 63C using the procedure described in the Chapter 2: Installation. Proceed as follows:

- * Switch the Computer on
- * On the DOS prompt, go to the C:\EDR\TPAS\DEMOS\ sub-directory
- * Run the BITWALK.EXE test program with parameter 700 where 700 is the base address of the PC 63C.

If an error message 'Board not found' appears on your screen then the PC 63C was not installed at that address. Try a different base address (eg: 700h) and re-run the test S/W. If the problem persists then try increasing the wait state on the PC 63C Board and rerun test software. The board should work.

If the PC 63C is found, a message will appear on the screen: 'PC 63C Board found'. The program will then step thru the reed relays starting from Relay 1 thru Relay 16. The LEDs corresponding to the reed relays will also light up to indicate that the PC 63C is working correctly.

Chapter 7: Troubleshooting

Problem: No $\pm 12V$ or $+5V$ supply voltages are seen on the DB37 Connector.

Solution: The supply line might have been overloaded or short circuited. Check the pico fuses F1 ($+12V$) and F2 ($+5V$). This can be done by running a continuity check across the terminal of the fuses. If the continuity check fails, then replace the fuse.

Problem: 'Board not found' message appears on the screen when running test software.

Solution: Another I/O card might be using the same base address location as the PC 63C. Try a different base address other than the manufacturers default base address (eg: 700h) and re-run test software. If the problem persists then try increasing the wait states on the PC 63C. If the PC 63C still does not work even after the maximum number of wait states was chosen then try a different computer. If the test still fails then the PC 63C is faulty. Return the board to your distributor for repairs.

Problem: Readback registers on Port A (Relay 1 thru 8) and Port B (relays 9 thru 16) gives incorrect results.

Solution: Another I/O card might be using the same base address location as the PC 63C. Try a different base address other than the manufacturers default base address (eg: 700h) and re-run test software or your application program. If the problem persists then return the PC 63C Board for repairs.

Problem: Readback register states that a specified Reed Relay should be ON. However, the reed relay does not appear to be switching.

Solution: The specified REED relay might be faulty. The probable cause might be that the maximum voltage / current rating was exceeded. Return to your distributor for repairs.

Problem: System hangs as soon as the application load voltage is switched.

Solution: The back EMF induced by the load is too high. Check if the maximum load voltage was exceeded. If so, reduce load voltage within specification.

If you cannot solve the problem then simply call your distributor for immediate help.

Chapter 8: Repair Service

The PC 63C is guaranteed for a period of 1 year. If the board is faulty within this period, we will gladly repair it free of charge provided that the maximum specifications was not exceeded. If any burn't tracks are seen on the PC 63C Board, warranty will be void. A repair charge will be levied in the user requires the board to be repaired

Before sending the board to your distributor for repairs, ensure that you go through Chapter 5 Troubleshooting Hints thoroughly. If after you have gone through this Chapter, the board does not work, return it for repairs stating in detail what the problem is.

Our repair service centre will be available to repair our products even after the 1 year warranty. A small service fee will be levied which usually covers the cost of the components that are faulty.

Specifications

Computer Host Interface

<i>Base Address:</i>	Switchable from 0 to 07F8h on 8 byte boundaries
<i>Bus Type:</i>	XT, AT, ISA or EISA
<i>I/O Wait States:</i>	0, 2, 4, or 8 Jumper selectable.
<i>Number of Registers:</i>	Four 8-bit
<i>Interrupts:</i>	Jumper selectable from IRQ 2 thru IRQ7
<i>Power Requirements:</i>	+5V DC at $\pm 800\text{mA}$ Max

External Interface

<i>Number of reed relays:</i>	16
<i>Relay contact rating:</i>	Power 10W (max) Switching Voltage 150V DC (max) Carry current 1.25A (max) Switching current 1A (max) Contact resistance: 0.15 Ω
<i>Relay coil rating:</i>	Nominal ON Voltage: 5V DC Min ON voltage: 3.8V DC Min OFF Voltage: 0.5V DC Coil resistance: 500 Ω $\pm 10\%$
<i>Breakdown Voltage:</i>	between open contacts 250V DC (min) between contact & coil 500V DC (min)
<i>Relay Release time</i>	0.2mSec (max)
<i>Relay General Data:</i>	Shock: 35g Vibration: 20g Operating Temp: -20°C to 70°C Storage Temp: -25°C to +85°C
<i>Trigger Line</i>	
<i>Input voltage:</i>	0 to 3V logical low 3.1V to 24V logical high
<i>Max reverse voltage:</i>	400V peak
<i>Max input current:</i>	1A peak 30mA continuous
<i>Signal frequency response:</i>	10kHz
<i>Interrupt link:</i>	Jumper selectable from IRQ2 thru IRQ7
<i>I/O connector:</i>	37-way female DB37 Amphenol
<i>Power Requirements:</i>	+5V DC at $\pm 800\text{mA}$ Max

Environmental

<i>Operating temperature:</i>	0°C to 55°C
<i>Storage temperature:</i>	-55°C to 150°C
<i>Relative humidity:</i>	5% to 90% non-condensing
<i>Board size:</i>	170mm x 106mm

Appendix A

Base Address Switch Settings

Base Address	SW1	SW2	SW3	SW4	SW5	SW6	SW7	SW8	Base Address
00	ON	ON	ON	ON	ON	ON	ON	ON	00
08	ON	ON	ON	ON	ON	ON	ON	OFF	08
10	ON	ON	ON	ON	ON	ON	OFF	ON	10
18	ON	ON	ON	ON	ON	ON	OFF	OFF	18
20	ON	ON	ON	ON	ON	OFF	ON	ON	20
28	ON	ON	ON	ON	ON	OFF	ON	OFF	28
30	ON	ON	ON	ON	ON	OFF	OFF	ON	30
38	ON	ON	ON	ON	ON	OFF	OFF	OFF	38
40	ON	ON	ON	ON	OFF	ON	ON	ON	40
48	ON	ON	ON	ON	OFF	ON	ON	OFF	48
50	ON	ON	ON	ON	OFF	ON	OFF	ON	50
58	ON	ON	ON	ON	OFF	ON	OFF	OFF	58
60	ON	ON	ON	ON	OFF	OFF	ON	ON	60
68	ON	ON	ON	ON	OFF	OFF	ON	OFF	68
70	ON	ON	ON	ON	OFF	OFF	OFF	ON	70
78	ON	ON	ON	ON	OFF	OFF	OFF	OFF	78
80	ON	ON	ON	OFF	ON	ON	ON	ON	80
88	ON	ON	ON	OFF	ON	ON	ON	OFF	88
90	ON	ON	ON	OFF	ON	ON	OFF	ON	90
98	ON	ON	ON	OFF	ON	ON	OFF	OFF	98
A0	ON	ON	ON	OFF	ON	OFF	ON	ON	A0
A8	ON	ON	ON	OFF	ON	OFF	ON	OFF	A8
B0	ON	ON	ON	OFF	ON	OFF	OFF	ON	B0
B8	ON	ON	ON	OFF	ON	OFF	OFF	OFF	B8
C0	ON	ON	ON	OFF	OFF	ON	ON	ON	C0
C8	ON	ON	ON	OFF	OFF	ON	ON	OFF	C8
D0	ON	ON	ON	OFF	OFF	ON	OFF	ON	D0
D8	ON	ON	ON	OFF	OFF	ON	OFF	OFF	D8
E0	ON	ON	ON	OFF	OFF	OFF	ON	ON	E0
E8	ON	ON	ON	OFF	OFF	OFF	ON	OFF	E8
F0	ON	ON	ON	OFF	OFF	OFF	OFF	ON	F0
F8	ON	ON	ON	OFF	OFF	OFF	OFF	OFF	F8
100	ON	ON	OFF	ON	ON	ON	ON	ON	100
108	ON	ON	OFF	ON	ON	ON	ON	OFF	108
110	ON	ON	OFF	ON	ON	ON	OFF	ON	110
118	ON	ON	OFF	ON	ON	ON	OFF	OFF	118
120	ON	ON	OFF	ON	ON	OFF	ON	ON	120
128	ON	ON	OFF	ON	ON	OFF	ON	OFF	128
130	ON	ON	OFF	ON	ON	OFF	OFF	ON	130
138	ON	ON	OFF	ON	ON	OFF	OFF	OFF	138
140	ON	ON	OFF	ON	OFF	ON	ON	ON	140
148	ON	ON	OFF	ON	OFF	ON	ON	OFF	148
150	ON	ON	OFF	ON	OFF	ON	OFF	ON	150
158	ON	ON	OFF	ON	OFF	ON	OFF	OFF	158

Base Address	SW1	SW2	SW3	SW4	SW5	SW6	SW7	SW8	Base Address
160	ON	ON	OFF	ON	OFF	OFF	ON	ON	160
168	ON	ON	OFF	ON	OFF	OFF	ON	OFF	168
170	ON	ON	OFF	ON	OFF	OFF	OFF	ON	170
178	ON	ON	OFF	ON	OFF	OFF	OFF	OFF	178
180	ON	ON	OFF	OFF	ON	ON	ON	ON	180
188	ON	ON	OFF	OFF	ON	ON	ON	OFF	188
190	ON	ON	OFF	OFF	ON	ON	OFF	ON	190
198	ON	ON	OFF	OFF	ON	ON	OFF	OFF	198
1A0	ON	ON	OFF	OFF	ON	OFF	ON	ON	1A0
1A8	ON	ON	OFF	OFF	ON	OFF	ON	OFF	1A8
1B0	ON	ON	OFF	OFF	ON	OFF	OFF	ON	1B0
1B8	ON	ON	OFF	OFF	ON	OFF	OFF	OFF	1B8
1C0	ON	ON	OFF	OFF	OFF	ON	ON	ON	1C0
1C8	ON	ON	OFF	OFF	OFF	ON	ON	OFF	1C8
1D0	ON	ON	OFF	OFF	OFF	ON	OFF	ON	1D0
1D8	ON	ON	OFF	OFF	OFF	ON	OFF	OFF	1D8
1E0	ON	ON	OFF	OFF	OFF	OFF	ON	ON	1E0
1E8	ON	ON	OFF	OFF	OFF	OFF	ON	OFF	1E8
1F0	ON	ON	OFF	OFF	OFF	OFF	OFF	ON	1F0
1F8	ON	ON	OFF	OFF	OFF	OFF	OFF	OFF	1F8
200	ON	OFF	ON	ON	ON	ON	ON	ON	200
208	ON	OFF	ON	ON	ON	ON	ON	OFF	208
210	ON	OFF	ON	ON	ON	ON	OFF	ON	210
218	ON	OFF	ON	ON	ON	ON	OFF	OFF	218
220	ON	OFF	ON	ON	ON	OFF	ON	ON	220
228	ON	OFF	ON	ON	ON	OFF	ON	OFF	228
230	ON	OFF	ON	ON	ON	OFF	OFF	ON	230
238	ON	OFF	ON	ON	ON	OFF	OFF	OFF	238
240	ON	OFF	ON	ON	OFF	ON	ON	ON	240
248	ON	OFF	ON	ON	OFF	ON	ON	OFF	248
250	ON	OFF	ON	ON	OFF	ON	OFF	ON	250
258	ON	OFF	ON	ON	OFF	ON	OFF	OFF	258
260	ON	OFF	ON	ON	OFF	OFF	ON	ON	260
268	ON	OFF	ON	ON	OFF	OFF	ON	OFF	268
270	ON	OFF	ON	ON	OFF	OFF	OFF	ON	270
278	ON	OFF	ON	ON	OFF	OFF	OFF	OFF	278
280	ON	OFF	ON	OFF	ON	ON	ON	ON	280
288	ON	OFF	ON	OFF	ON	ON	ON	OFF	288
290	ON	OFF	ON	OFF	ON	ON	OFF	ON	290
298	ON	OFF	ON	OFF	ON	ON	OFF	OFF	298
2A0	ON	OFF	ON	OFF	ON	OFF	ON	ON	2A0
2A8	ON	OFF	ON	OFF	ON	OFF	ON	OFF	2A8
2B0	ON	OFF	ON	OFF	ON	OFF	OFF	ON	2B0
2B8	ON	OFF	ON	OFF	ON	OFF	OFF	OFF	2B8
2C0	ON	OFF	ON	OFF	OFF	ON	ON	ON	2C0
2C8	ON	OFF	ON	OFF	OFF	ON	ON	OFF	2C8
2D0	ON	OFF	ON	OFF	OFF	ON	OFF	ON	2D0
2D8	ON	OFF	ON	OFF	OFF	ON	OFF	OFF	2D8
2E0	ON	OFF	ON	OFF	OFF	OFF	ON	ON	2E0
2E8	ON	OFF	ON	OFF	OFF	OFF	ON	OFF	2E8
2F0	ON	OFF	ON	OFF	OFF	OFF	OFF	ON	2F0
2F8	ON	OFF	ON	OFF	OFF	OFF	OFF	OFF	2F8

Base Address	SW1	SW2	SW3	SW4	SW5	SW6	SW7	SW8	Base Address
300	ON	OFF	OFF	ON	ON	ON	ON	ON	300
308	ON	OFF	OFF	ON	ON	ON	ON	OFF	308
310	ON	OFF	OFF	ON	ON	ON	OFF	ON	310
318	ON	OFF	OFF	ON	ON	ON	OFF	OFF	318
320	ON	OFF	OFF	ON	ON	OFF	ON	ON	320
328	ON	OFF	OFF	ON	ON	OFF	ON	OFF	328
330	ON	OFF	OFF	ON	ON	OFF	OFF	ON	330
338	ON	OFF	OFF	ON	ON	OFF	OFF	OFF	338
340	ON	OFF	OFF	ON	OFF	ON	ON	ON	340
348	ON	OFF	OFF	ON	OFF	ON	ON	OFF	348
350	ON	OFF	OFF	ON	OFF	ON	OFF	ON	350
358	ON	OFF	OFF	ON	OFF	ON	OFF	OFF	358
360	ON	OFF	OFF	ON	OFF	OFF	ON	ON	360
368	ON	OFF	OFF	ON	OFF	OFF	ON	OFF	368
370	ON	OFF	OFF	ON	OFF	OFF	OFF	ON	370
378	ON	OFF	OFF	ON	OFF	OFF	OFF	OFF	378
380	ON	OFF	OFF	OFF	ON	ON	ON	ON	380
388	ON	OFF	OFF	OFF	ON	ON	ON	OFF	388
390	ON	OFF	OFF	OFF	ON	ON	OFF	ON	390
398	ON	OFF	OFF	OFF	ON	ON	OFF	OFF	398
3A0	ON	OFF	OFF	OFF	ON	OFF	ON	ON	3A0
3A8	ON	OFF	OFF	OFF	ON	OFF	ON	OFF	3A8
3B0	ON	OFF	OFF	OFF	ON	OFF	OFF	ON	3B0
3B8	ON	OFF	OFF	OFF	ON	OFF	OFF	OFF	3B8
3C0	ON	OFF	OFF	OFF	OFF	ON	ON	ON	3C0
3C8	ON	OFF	OFF	OFF	OFF	ON	ON	OFF	3C8
3D0	ON	OFF	OFF	OFF	OFF	ON	OFF	ON	3D0
3D8	ON	OFF	OFF	OFF	OFF	ON	OFF	OFF	3D8
3E0	ON	OFF	OFF	OFF	OFF	OFF	ON	ON	3E0
3E8	ON	OFF	OFF	OFF	OFF	OFF	ON	OFF	3E8
3F0	ON	OFF	OFF	OFF	OFF	OFF	OFF	ON	3F0
3F8	ON	OFF	OFF	OFF	OFF	OFF	OFF	OFF	3F8
400	OFF	ON	ON	ON	ON	ON	ON	ON	400
408	OFF	ON	ON	ON	ON	ON	ON	OFF	408
410	OFF	ON	ON	ON	ON	ON	OFF	ON	410
418	OFF	ON	ON	ON	ON	ON	OFF	OFF	418
420	OFF	ON	ON	ON	ON	OFF	ON	ON	420
428	OFF	ON	ON	ON	ON	OFF	ON	OFF	428
430	OFF	ON	ON	ON	ON	OFF	OFF	ON	430
438	OFF	ON	ON	ON	ON	OFF	OFF	OFF	438
440	OFF	ON	ON	ON	OFF	ON	ON	ON	440
448	OFF	ON	ON	ON	OFF	ON	ON	OFF	448
450	OFF	ON	ON	ON	OFF	ON	OFF	ON	450
458	OFF	ON	ON	ON	OFF	ON	OFF	OFF	458
460	OFF	ON	ON	ON	OFF	OFF	ON	ON	460
468	OFF	ON	ON	ON	OFF	OFF	ON	OFF	468
470	OFF	ON	ON	ON	OFF	OFF	OFF	ON	470
478	OFF	ON	ON	ON	OFF	OFF	OFF	OFF	478
480	OFF	ON	ON	OFF	ON	ON	ON	ON	480
488	OFF	ON	ON	OFF	ON	ON	ON	OFF	488
490	OFF	ON	ON	OFF	ON	ON	OFF	ON	490
498	OFF	ON	ON	OFF	ON	ON	OFF	OFF	498

Base Address	SW1	SW2	SW3	SW4	SW5	SW6	SW7	SW8	Base Address
4A0	OFF	ON	ON	OFF	ON	OFF	ON	ON	4A0
4A8	OFF	ON	ON	OFF	ON	OFF	ON	OFF	4A8
4B0	OFF	ON	ON	OFF	ON	OFF	OFF	ON	4B0
4B8	OFF	ON	ON	OFF	ON	OFF	OFF	OFF	4B8
4C0	OFF	ON	ON	OFF	OFF	ON	ON	ON	4C0
4C8	OFF	ON	ON	OFF	OFF	ON	ON	OFF	4C8
4D0	OFF	ON	ON	OFF	OFF	ON	OFF	ON	4D0
4D8	OFF	ON	ON	OFF	OFF	ON	OFF	OFF	4D8
4E0	OFF	ON	ON	OFF	OFF	OFF	ON	ON	4E0
4E8	OFF	ON	ON	OFF	OFF	OFF	ON	OFF	4E8
4F0	OFF	ON	ON	OFF	OFF	OFF	OFF	ON	4F0
4F8	OFF	ON	ON	OFF	OFF	OFF	OFF	OFF	4F8
500	OFF	ON	OFF	ON	ON	ON	ON	ON	500
508	OFF	ON	OFF	ON	ON	ON	ON	OFF	508
510	OFF	ON	OFF	ON	ON	ON	OFF	ON	510
518	OFF	ON	OFF	ON	ON	ON	OFF	OFF	518
520	OFF	ON	OFF	ON	ON	OFF	ON	ON	520
528	OFF	ON	OFF	ON	ON	OFF	ON	OFF	528
530	OFF	ON	OFF	ON	ON	OFF	OFF	ON	530
538	OFF	ON	OFF	ON	ON	OFF	OFF	OFF	538
540	OFF	ON	OFF	ON	OFF	ON	ON	ON	540
548	OFF	ON	OFF	ON	OFF	ON	ON	OFF	548
550	OFF	ON	OFF	ON	OFF	ON	OFF	ON	550
558	OFF	ON	OFF	ON	OFF	ON	OFF	OFF	558
560	OFF	ON	OFF	ON	OFF	OFF	ON	ON	560
568	OFF	ON	OFF	ON	OFF	OFF	ON	OFF	568
570	OFF	ON	OFF	ON	OFF	OFF	OFF	ON	570
578	OFF	ON	OFF	ON	OFF	OFF	OFF	OFF	578
580	OFF	ON	OFF	OFF	ON	ON	ON	ON	580
588	OFF	ON	OFF	OFF	ON	ON	ON	OFF	588
590	OFF	ON	OFF	OFF	ON	ON	OFF	ON	590
598	OFF	ON	OFF	OFF	ON	ON	OFF	OFF	598
5A0	OFF	ON	OFF	OFF	ON	OFF	ON	ON	5A0
5A8	OFF	ON	OFF	OFF	ON	OFF	ON	OFF	5A8
5B0	OFF	ON	OFF	OFF	ON	OFF	OFF	ON	5B0
5B8	OFF	ON	OFF	OFF	ON	OFF	OFF	OFF	5B8
5C0	OFF	ON	OFF	OFF	OFF	ON	ON	ON	5C0
5C8	OFF	ON	OFF	OFF	OFF	ON	ON	OFF	5C8
5D0	OFF	ON	OFF	OFF	OFF	ON	OFF	ON	5D0
5D8	OFF	ON	OFF	OFF	OFF	ON	OFF	OFF	5D8
5E0	OFF	ON	OFF	OFF	OFF	OFF	ON	ON	5E0
5E8	OFF	ON	OFF	OFF	OFF	OFF	ON	OFF	5E8
5F0	OFF	ON	OFF	OFF	OFF	OFF	OFF	ON	5F0
5F8	OFF	ON	OFF	OFF	OFF	OFF	OFF	OFF	5F8
600	OFF	OFF	ON	ON	ON	ON	ON	ON	600
608	OFF	OFF	ON	ON	ON	ON	ON	OFF	608
610	OFF	OFF	ON	ON	ON	ON	OFF	ON	610
618	OFF	OFF	ON	ON	ON	ON	OFF	OFF	618
620	OFF	OFF	ON	ON	ON	OFF	ON	ON	620
628	OFF	OFF	ON	ON	ON	OFF	ON	OFF	628
630	OFF	OFF	ON	ON	ON	OFF	OFF	ON	630
638	OFF	OFF	ON	ON	ON	OFF	OFF	OFF	638

Base Address	SW1	SW2	SW3	SW4	SW5	SW6	SW7	SW8	Base Address
640	OFF	OFF	ON	ON	OFF	ON	ON	ON	640
648	OFF	OFF	ON	ON	OFF	ON	ON	OFF	648
650	OFF	OFF	ON	ON	OFF	ON	OFF	ON	650
658	OFF	OFF	ON	ON	OFF	ON	OFF	OFF	658
660	OFF	OFF	ON	ON	OFF	OFF	ON	ON	660
668	OFF	OFF	ON	ON	OFF	OFF	ON	OFF	668
670	OFF	OFF	ON	ON	OFF	OFF	OFF	ON	670
678	OFF	OFF	ON	ON	OFF	OFF	OFF	OFF	678
680	OFF	OFF	ON	OFF	ON	ON	ON	ON	680
688	OFF	OFF	ON	OFF	ON	ON	ON	OFF	688
690	OFF	OFF	ON	OFF	ON	ON	OFF	ON	690
698	OFF	OFF	ON	OFF	ON	ON	OFF	OFF	698
6A0	OFF	OFF	ON	OFF	ON	OFF	ON	ON	6A0
6A8	OFF	OFF	ON	OFF	ON	OFF	ON	OFF	6A8
6B0	OFF	OFF	ON	OFF	ON	OFF	OFF	ON	6B0
6B8	OFF	OFF	ON	OFF	ON	OFF	OFF	OFF	6B8
6C0	OFF	OFF	ON	OFF	OFF	ON	ON	ON	6C0
6C8	OFF	OFF	ON	OFF	OFF	ON	ON	OFF	6C8
6D0	OFF	OFF	ON	OFF	OFF	ON	OFF	ON	6D0
6D8	OFF	OFF	ON	OFF	OFF	ON	OFF	OFF	6D8
6E0	OFF	OFF	ON	OFF	OFF	OFF	ON	ON	6E0
6E8	OFF	OFF	ON	OFF	OFF	OFF	ON	OFF	6E8
6F0	OFF	OFF	ON	OFF	OFF	OFF	OFF	ON	6F0
6F8	OFF	OFF	ON	OFF	OFF	OFF	OFF	OFF	6F8
700	OFF	OFF	OFF	ON	ON	ON	ON	ON	700
708	OFF	OFF	OFF	ON	ON	ON	ON	OFF	708
710	OFF	OFF	OFF	ON	ON	ON	OFF	ON	710
718	OFF	OFF	OFF	ON	ON	ON	OFF	OFF	718
720	OFF	OFF	OFF	ON	ON	OFF	ON	ON	720
728	OFF	OFF	OFF	ON	ON	OFF	ON	OFF	728
730	OFF	OFF	OFF	ON	ON	OFF	OFF	ON	730
738	OFF	OFF	OFF	ON	ON	OFF	OFF	OFF	738
740	OFF	OFF	OFF	ON	OFF	ON	ON	ON	740
748	OFF	OFF	OFF	ON	OFF	ON	ON	OFF	748
750	OFF	OFF	OFF	ON	OFF	ON	OFF	ON	750
758	OFF	OFF	OFF	ON	OFF	ON	OFF	OFF	758
760	OFF	OFF	OFF	ON	OFF	OFF	ON	ON	760
768	OFF	OFF	OFF	ON	OFF	OFF	ON	OFF	768
770	OFF	OFF	OFF	ON	OFF	OFF	OFF	ON	770
778	OFF	OFF	OFF	ON	OFF	OFF	OFF	OFF	778
780	OFF	OFF	OFF	OFF	ON	ON	ON	ON	780
788	OFF	OFF	OFF	OFF	ON	ON	ON	OFF	788
790	OFF	OFF	OFF	OFF	ON	ON	OFF	ON	790
798	OFF	OFF	OFF	OFF	ON	ON	OFF	OFF	798
7A0	OFF	OFF	OFF	OFF	ON	OFF	ON	ON	7A0
7A8	OFF	OFF	OFF	OFF	ON	OFF	ON	OFF	7A8
7B0	OFF	OFF	OFF	OFF	ON	OFF	OFF	ON	7B0
7B8	OFF	OFF	OFF	OFF	ON	OFF	OFF	OFF	7B8
7C0	OFF	OFF	OFF	OFF	OFF	ON	ON	ON	7C0
7C8	OFF	OFF	OFF	OFF	OFF	ON	ON	OFF	7C8
7D0	OFF	OFF	OFF	OFF	OFF	ON	OFF	ON	7D0
7D8	OFF	OFF	OFF	OFF	OFF	ON	OFF	OFF	7D8
7E0	OFF	OFF	OFF	OFF	OFF	OFF	ON	ON	7E0
7E8	OFF	OFF	OFF	OFF	OFF	OFF	ON	OFF	7E8
7F0	OFF	OFF	OFF	OFF	OFF	OFF	OFF	ON	7F0
7F8	OFF	OFF	OFF	OFF	OFF	OFF	OFF	OFF	7F8

Appendix B