

Title PCI-773 (16 CHANNEL) RTD Adapter		EAGLE TECHNOLOGY 31-35 HOUT STREET CAPE TOWN WESTERN PROVINCE RSA 8001		
Size: Orcad B	Number: PCI-773-R_1	Revision: 1A		
File: G:\PCB DESIGNS\Designs\PCI-773-16-Channel-RTD-Adapter-173306_20081117.dwg Time: 15:10:58 Sheet 2 of 3				

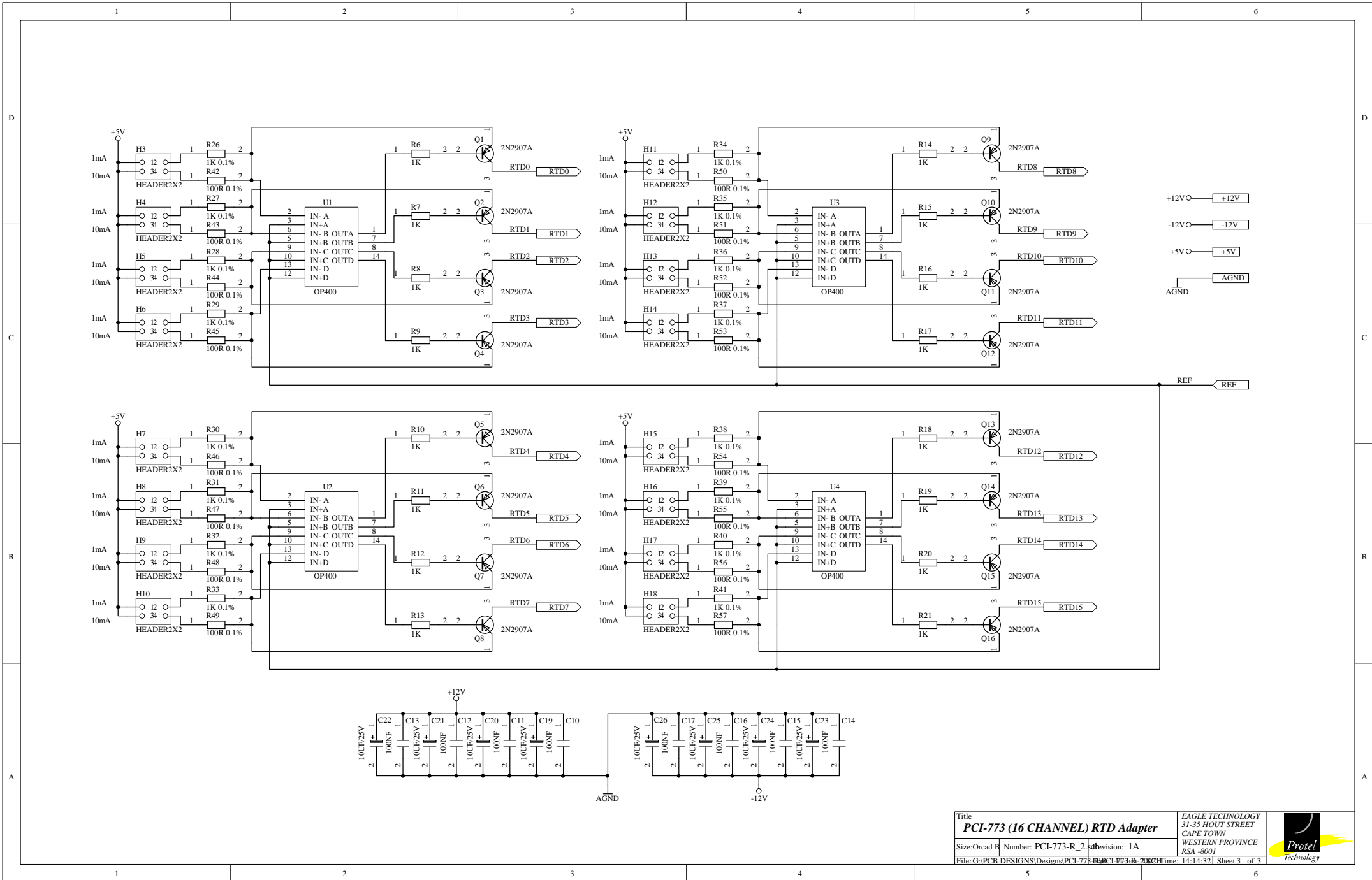

Title		EAGLE TECHNOLOGY 31-35 HOUT STREET CAPE TOWN WESTERN PROVINCE RSA 8001
PCI-773 (16 CHANNEL) RTD Adapter		
Size: Orcaad B	Number: PCI-773-R_2	Revision: 1A
File: G:\PCB DESIGNS\Designs\PCI-773-R_2\PCB1-773-16_200811\Time: 14:14:32\ Sheet 3 of 3		

