

Length measurement board, optically isolated, 16-bit, 16 or 8 inductive transducers, LVDT, half-bridge

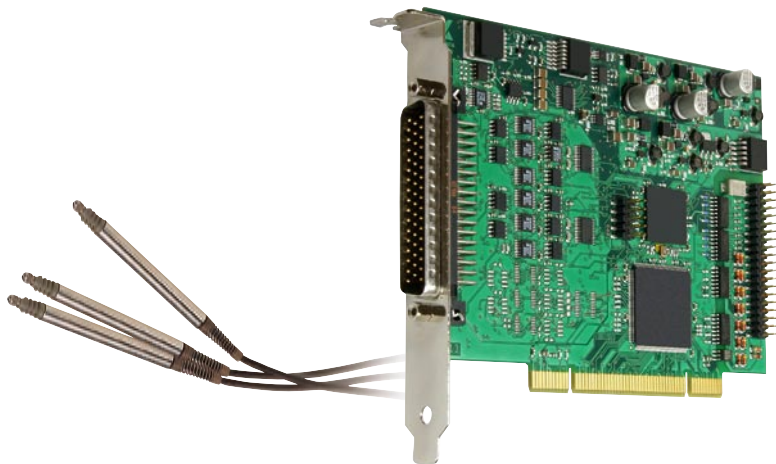

RoHS
compliant



The analog input board APCI-3701 allows the direct connection and fast acquisition of up to 16 half-bridge or LVDT transducers. The SET3701 calibration tool guides you through each step of the installation beginning with the selection of a transducer from a database including more than 50 pre-calibrated transducers up to testing each single channel. You can also update the APCI-3701 firmware with this program.

Features

- PCI 3.3 V or 5 V
- Acquisition of 8 or 16 inductive displacement transducers (half-bridge, LVDT)
- 16-bit resolution
- Sampling frequency depending on the transducer type from 2 to 20 kHz.
- Measuring frequency, programmable through software from 2 to 20 kHz (50 kHz on request).
- Conversion can be triggered through software, digital input or timer
- End of conversion through software and/or interrupt
- PCI-DMA access
- On-board FIFO
- Sequence RAM
- 16 digital I/O channels, isolated, 24 V
- Connection of the transducers through an external box (PX 3701-8 or -16 incl. cable). The box type depends on the transducer used; order separately
- Software operation
- Automatic setting of the input levels (Gain and Offset) acc. to transducer sensitivity
- Tool for individual database-managed calibration of the transducers
- Database for connecting/calibrating a large range of predefined transducers (APCI-3701-8, or -16):
 - Solartron • Tesa • Marposs • Schlumberger
 - Peter & Hirt • Mahr • RDP • Schaevitz
 - SMPR ControleOther transducers like for example Horst Knaebel can be calibrated on request.

Safety features

- Input filters
- Diagnostic function in case of short-circuit or line break

APCI-3701

Acquisition of 8 or 16 inductive displacement transducers

Half-bridge, LVDT

16-bit resolution

16 isolated digital I/O, 24 V

Measurement of different transducer types with the same board!

EMC tested acc. to 89/336/EEC

- IEC 61326: electrical equipment for measurement, control and laboratory use

Applications

- Gear wheel control
- Gauge block
- Acquisition of sensor data
- Quality assurance
- Industrial process control
- Automatic parts control
- R&D instrumentation

Software

SET3701 calibration tool (supplied with the board)

- Easy transducer calibration
- Step by step from the transducer selection up to testing each single channel
- Database with more than 50 pre-calibrated transducers
- Update of the APCI-3701 firmware

Software drivers for

Windows XP/2000/NT/98.

Real-time drivers for Windows XP/2000/NT/98.

The board is supplied with **ADDIPACK**.

Samples for the following compilers:

Microsoft VC++ 5.0 • Borland C++ 5.01

ADDIPACK functions supported:

Transducer • Timer • Digital input • Digital output

Current driver list on the web: www.addi-data.com



Connection box for transducers

www.addi-data.com

Phone: +49(0)7223/9493-0
Fax: +49(0)7223/9493-97

Length measurement board, optically isolated, 16-bit, 16 or 8 inductive transducers, LVDT, half-bridge



APCI-3701

Specifications

Analog inputs	
Number of inputs:	for 8 or 16 inductive displacement transducers
Resolution:	16-bit
Interrupt:	At end of conversion, timer overrun or end of scan, DMA Short circuit on the transducer supply
Programmable modes:	- Trigger (external, through digital input) - Interrupt - Polling - DMA - Autorefresh
Conversion start:	Triggering through software (API function), timer-driven or digital input
End of conversion:	Readable through software or interruption
Timer:	1 x 16-bit
Diagnostic possibilities:	Short circuit or break of the transducer supply Short circuit or break of the transducer signal line
Digital I/O	
Number of I/O channels:	8 digital inputs, 8 digital outputs, 24 V
Optical isolation:	1000 V through opto-couplers
Inputs current at 24 V:	3 mA typ.
Max. input frequency:	5 kHz
Max. switching current:	50 mA typ.
Input range:	0-30 V
Output range:	5-30 V
Noise immunity	
Test level:	- ESD: 4 kV - Fields: 10 V/m - Burst: 2 kV/4 kV Netz - Conducted radio interferences: 10 V
Physical and environmental conditions	
Dimensions:	140 x 99 mm
System bus:	PCI 32-bit 5 V/3.3 V acc. to spec. 2.2 (PCISiG)
Space required:	1 PCI slot for analog inputs, 1 slot opening for digital I/O with FB3701
Operating voltage:	+ 5 V, ± 5 % from PC; 24 V external
Current consumption (+ 5 V PC):	APCI-3701-8: 1.28 A ± 5 % APCI-3701-16: 1.40 A ± 5 %
Front connector:	50-pin SUB-D male connector
Additional connector:	16-pin male connector for connecting the dig. I/O
Temperature range:	0 to 60 °C (with forced cooling)



Connection box for transducers

Simplified block diagram

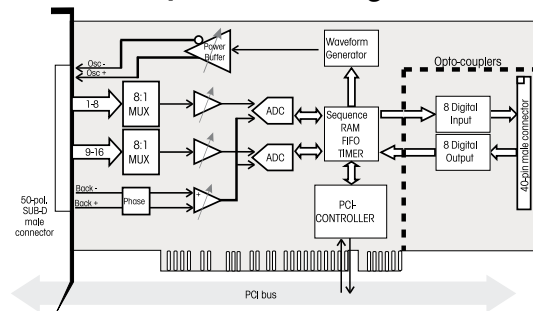

Pin assignment 50-pin SUB-D male connector (APCI-3701-16)

Pin	Pin	Pin	Pin
34 BACK+	18 BACK+	34	1 BACK+
35 BACK-	19 BACK-	35	2 BACK-
36 OSC+	20 OSC+	36	3 OSC+
37 OSC+	21 OSC+	37	4 OSC+
38 OSC-	22 OSC-	38	5 OSC-
39 PWRGND	23 OSC-	39	6 OSC-
40 CH0	24 PWRGND	40	7 PWRGND
41 PWRGND	25 CH2	41	8 CH1
42 CH3	26 PWRGND	42	9 PWRGND
43 PWRGND	27 CH5	43	10 CH4
44 CH6	28 PWRGND	44	11 PWRGND
45 PWRGND	29 CH8	45	12 CH7
46 CH9	30 PWRGND	46	13 PWRGND
47 PWRGND	31 CH11	47	14 CH10
48 CH12	32 PWRGND	48	15 PWRGND
49 PWRGND	33 CH14	49	16 CH13
50 CH15		50	17 PWRGND

Osc+/-: Phase-shifted supply signal of the inductive transducers
 Back+/-: Return lines of the supply voltage for measuring the amplitude.
 It serves as true value signal of the oscillator for the supply voltage.
 CHx: Transducer input and input number
 PWRGND: Ground

ADDI-DATA connection

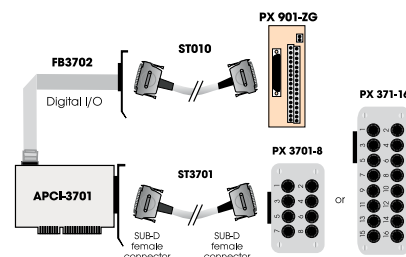

ORDERING INFORMATION

APCI-3701

Length measurement board, optically isolated, 16-bit, 16 or 8 inductive transducers, LVDT, half-bridge.
 Incl. technical description and software driver.

APCI-3701-8: For 8 displacement transducers
APCI-3701-16: For 16 displacement transducers

Connection:

FB3702: Ribbon cable for digital I/O
PX 901-ZG: Terminal panel for digital I/O
ST010: Standard round cable, shielded, twisted pairs, 2 m

Connection for HB and LVDT transducers:

PX 3701-HB-8: Connection box of the APCI-3701-8, for 8 half-bridge transducers
PX 3701-HB-16: Connection box of the APCI-3701-16 for 16 half-bridge transducers
PX 3701-LVDT-8: Connection box of the APCI-3701-8 for 8 LVDT transducers
PX 3701-LVDT-16: Connection box of the APCI-3701-16 for 16 LVDT transducers
ST3701: Connection cable between APCI-3701 and connection box PX 3701