

Watchdog board, optically isolated, 4 watchdogs/timers

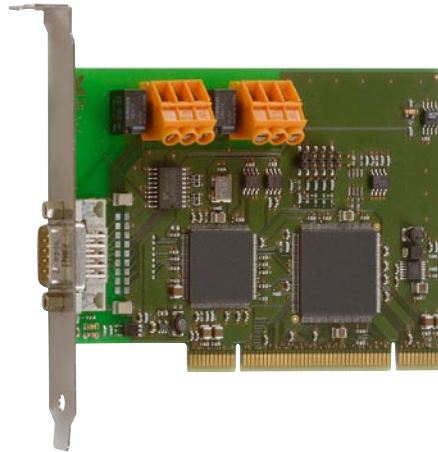

PCI 32-bit



LabVIEW™



LabWindows/CVI™

Maximise the reliability of your telecom, ISP, Voice Mail, File Server or industrial systems under Windows operating systems with the APCI-035 PCI watchdog board.

The board is equipped with 4 watchdogs which can monitor software and hardware tasks independently from each other.

The PCI watchdog board APCI-035 has a two-level alarm system and can initiate a hardware reset in case of emergency. The principle is based on the computer software having to send signals to the board at regular intervals. If the board does not receive an expected signal within a certain period of time, the first alarm level is activated. The emergency program is started which determines the cause and tries to remove the error. If this fails, the operating system and, if necessary, external devices are prepared for the hardware reset. The second alarm level is automatically triggered after a defined timeout.

Watchdog 1 can be programmed with 1 of 4 different time units (μ s, ms, s, min). The alarm levels are controlled through 1 trigger channel and 4 different time bases. The internal PC temperature can be monitored through the onboard temperature sensor.

Features

- PCI 3.3 V or 5 V

Watchdog

- 4 watchdogs/timers
- 1 trigger channel/gate input (24 V)
- Activation through software
- Configuration through software, readable
- Can be triggered through software or digital input
- Time base for the watchdog/timer: μ s, ms, s, min
- Two completely separated programmable alarm levels: Level 1 generates an interrupt or switches the warning relay, level 2 switches the reset relay.
- With the two-level alarm, the operating system can be warned through an interrupt that a hardware reset is going to take place. There is then enough time to close the active tasks.
- The alarm time can be read back at any time, so that the time remaining for further tasks can be established.
- Switching time of the reset relay: 2 s

APCI-035

4 watchdogs/timers

2 relays with change-over contacts

1 digital input, 24 V

2 alarm levels

Temperature monitoring

from - 45 °C to + 135 °C

Defined state after booting

- The watchdogs are switched off through the system reset

Diagnostic

- The status of the 4 watchdogs is readable
- 1 digital input (watchdog trigger or timer gate)
- Watchdog 1 can switch 2 software-controlled relays

Safety

- Optical isolation 500 V

Temperature measurement

- 1 temperature onboard sensor
- Alarm function when a programmable limit value is exceeded

Applications

- Control of industrial PC-based process
- Time measurement
- Timer-driven software applications
- Temperature monitoring

Software drivers

A CD-ROM with the following software and programming samples is supplied with the board.

Standard drivers for:

Linux Kernel version 2.4.2,
Windows Vista (32-bit)/XP/2000/NT/98

Real-time drivers for

Windows Vista (32-bit)/XP/2000/NT/98

The board is supplied with the universal software **ADDIPACK** (see page 8).

Drivers for the following software packages:

LabVIEW 5.01 • LabWindows/CVI 5.01

Samples for the following compilers:

Microsoft VC++ 5.0 • Borland C++ 5.01

Delphi 4.0 • Visual Basic 5.0

Softwarefunktionen for ADDIPACK:

Interrupt • Watchdog • Timer • Temperature

Free driver download on the web:

www.addi-data.com/download

Watchdog board, optically isolated, 4 watchdogs/timers

APCI-035

Specifications

APCI-035

Addressing:	32-bit
Addressing range:	256 Byte
Interrupt:	Über BIOS
Optical isolation:	500 V (from the PC to the peripheral)

Watchdog/timer

Depth:	8-bit
Switching time of the reset relays:	2 s
4 x programmable watchdogs/timers:	Time selectable from 2 μ s to 255 min
Time units:	μ s, ms, s, min

Temperature monitoring

Accuracy:	± 2 °C
Measurement range:	-45 °C to 135 °C (real range of application 0-60 °C)
Resolution:	8-bit

Relay data

Type of contacts:	2 change-over contacts
Max. switching voltage:	60 VAC, 48 VAC
Max. switching current:	1 A
Max. switching capacity:	62.5 VA, 30 W
Min. permissible load:	1 mA / 5 VAC
Nominal load:	1 A 24 VAC
Contact resistance:	< 100 m Ω
Contact material:	Ag + Au-plated
Responding time:	max. 5 ms, typ. 2.5 ms
Release time:	max. 5 ms, typ. 0.9 ms
Mechanical life:	5 x 10 ⁶ operations
Electrical life at 24 V:	10 ⁵ operations

Digital input

Nominal input current at 24 V:	6 mA
Nominal input voltage:	24 V
Switching threshold:	>16 V for logical "1".

EMC – Electromagnetic compatibility

The product complies with the European EMC directive. The tests were carried out by a certified EMC laboratory in accordance with the norm from the EN 61326 series (IEC 61326). The limit values as set out by the European EMC directive for an industrial environment are complied with. The respective EMC test report is available on request.

Physical and environmental conditions

Dimensions:	120 x 85 mm
System bus:	PCI 32-bit 3.3/5 V acc. to spec. 2.2 (PCISiG)
Space required:	1 PCI slot
Operating voltage:	+5 V, ± 5 % from the PC
Current consumption:	240 mA ± 10 % typ.
Front connector:	9-pin SUB-D male connector
Temperature range:	0 to 60 °C (with forced cooling)

Simplified block diagram

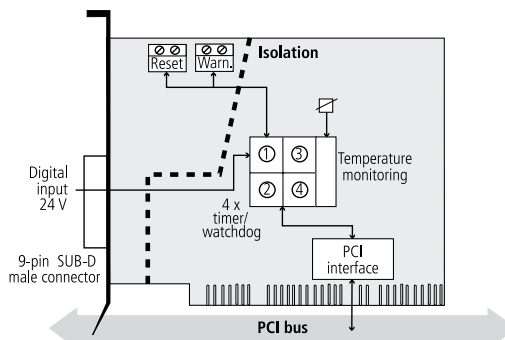

Einstellungsmöglichkeiten for das Alarmsystem

Function settings through software

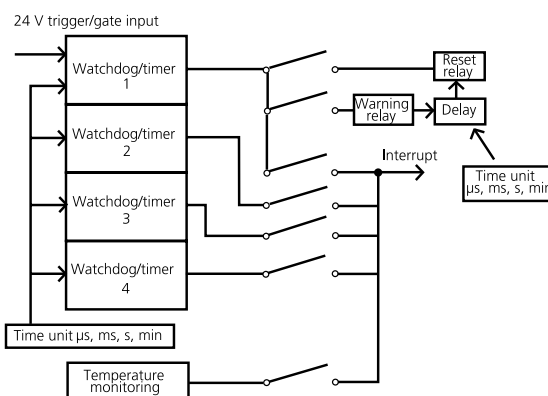

Level 1: Interrupt / warning relay
Level 2: Reset relay / reset generated through reset switch of the PC system

Pin assignment – 9-pin SUB-D male connector

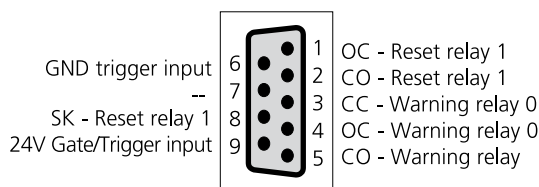

CO: Change-over contact
CC: Closer contact
OC: Opening contact

Ordering information

APCI-035

Watchdog board, optically isolated, 4 watchdogs/timers.
Incl. technical description and software drivers.